

USER GUIDE

Protempis[®] ThunderBolt[®] E GPS Disciplined Clock

Version 1.0
Revision E
Part Number 60333-XX
August 2021

Corporate Office

Protempis
USA
www.protempis.com

Email:
support@protempis.com

Legal Notices

Copyright and Trademarks

© 1998–2021, Protempis Inc. Protempis, the Globe & Triangle logo, and ThunderBolt are trademarks of Protempis Inc., registered in the United States and in other countries. Bullet and The right one logo are trademarks of Protempis Inc.

Microsoft and Windows are either registered trademarks or trademarks of Microsoft Corporation in the United States and/or other countries.

All other trademarks are the property of their respective owners

Release Notice

This is the August 2021 release (Revision E) of the *Protempis ThunderBolt E GPS Disciplined Clock User Guide*, part number 60333-XX.

See the website for updated part number information.

Product Limited Warranty Information

For applicable product Limited Warranty information, please consult your local Protempis authorized sales manager.

For applicable product Limited Warranty information, please refer to Legal Notices in the Help for this product, or consult your local Protempis authorized dealer.

LIMITED WARRANTY TERMS AND CONDITIONS

Product Limited Warranty

Subject to the following terms and conditions, Protempis Inc (“Protempis”) warrants that for a period of one (1) year from date of purchase this Protempis product (the “Product”) will substantially conform to Protempis’ publicly available specifications for the Product and that the hardware and any storage media components of the Product will be substantially free from defects in materials and workmanship.

Product Software

Product software, whether built into hardware circuitry as firmware, provided as a standalone computer software product, embedded in flash memory, or stored on magnetic or other media, is licensed solely for use with or as an integral part of the Product and is not sold. If accompanied by a separate end user license agreement (“EULA”), use of any such software will be subject to the terms of such end user license agreement (including any differing limited warranty terms, exclusions, and limitations), which shall control over the terms and conditions set forth in this limited warranty.

Software Fixes

During the limited warranty period you will be entitled to receive such Fixes to the Product software that Protempis releases and makes commercially available and for which it does not charge separately, subject to the procedures for delivery to purchasers of Protempis products generally. If you have purchased the Product from an authorized Protempis dealer rather than from Protempis directly, Protempis may, at its option, forward the software Fix to the Protempis dealer for final distribution to you. Minor Updates, Major Upgrades, new products, or substantially new software releases, as identified by Protempis, are expressly excluded from this update process and limited warranty. Receipt of software Fixes or other enhancements shall not serve to extend the limited warranty period.

For purposes of this warranty the following definitions shall apply:

- (1) “Fix(es)” means an error correction or other update created to fix a previous software version that does not substantially conform to its Protempis specifications;
- (2) “Minor Update” occurs when enhancements are made to current features in a software program;
- (3) “Major Upgrade” occurs when significant new features are added to software, or when a new product containing new features replaces the further development of a current product line. Protempis reserves the right to determine, in its sole discretion, what constitutes a Fix, Minor Update, or Major Upgrade.

Warranty Remedies

If the Protempis Product fails during the warranty period for reasons covered by this limited warranty and you notify Protempis of such failure during the warranty period, Protempis will repair OR replace the

nonconforming Product with new, equivalent to new, or reconditioned parts or Product, OR refund the Product purchase price paid by you, at Protempis’ option, upon your return of the Product in accordance with Protempis’ product return procedures then in effect.

How to Obtain Warranty Service

To obtain warranty service for the Product, please contact your local Protempis authorized dealer. Alternatively, you may contact Protempis to request warranty service by sending an email to support@protempis.com. Please be prepared to provide:

- your name, address, and telephone numbers
- proof of purchase
- a description of the nonconforming Product including the model number and serial number
- an explanation of the problem

The customer service representative may need additional information from you depending on the nature of the problem.

Warranty Exclusions and Disclaimer

This Product limited warranty shall only apply in the event and to the extent that (a) the Product is properly and correctly installed, configured, interfaced, maintained, stored, and operated in accordance with Protempis’ applicable operator’s manual and specifications, and; (b) the Product is not modified or misused. This Product limited warranty shall not apply to, and Protempis shall not be responsible for, defects or performance problems resulting from (i) the combination or utilization of the Product with hardware or software products, information, data, systems, interfaces, or devices not made, supplied, or specified by Protempis; (ii) the operation of the Product under any specification other than, or in addition to, Protempis’ standard specifications for its products; (iii) the unauthorized installation, modification, or use of the Product; (iv) damage caused by: accident, lightning or other electrical discharge, fresh or salt water immersion or spray (outside of Product specifications); or exposure to environmental conditions for which the Product is not intended; (v) normal wear and tear on consumable parts (e.g., batteries); or (vi) cosmetic damage. Protempis does not warrant or guarantee the results obtained through the use of the Product, or that software components will operate error free.

NOTICE REGARDING PRODUCTS EQUIPPED WITH TECHNOLOGY CAPABLE OF TRACKING SATELLITE SIGNALS FROM SATELLITE BASED AUGMENTATION SYSTEMS (SBAS) (WAAS/EGNOS, AND MSAS), OMNISTAR, GPS, MODERNIZED GPS OR GLONASS SATELLITES, OR FROM IALA BEACON SOURCES: PROTEMPIS IS NOT RESPONSIBLE FOR THE OPERATION OR FAILURE OF OPERATION OF ANY SATELLITE BASED POSITIONING SYSTEM OR THE AVAILABILITY OF ANY SATELLITE BASED POSITIONING SIGNALS.

THE FOREGOING LIMITED WARRANTY TERMS STATE PROTEMPIS’ ENTIRE LIABILITY, AND YOUR EXCLUSIVE REMEDIES, RELATING TO THE PROTEMPIS PRODUCT, EXCEPT AS OTHERWISE EXPRESSLY PROVIDED HEREIN, THE PRODUCT, AND ACCOMPANYING DOCUMENTATION AND MATERIALS ARE PROVIDED “AS-IS” AND WITHOUT EXPRESS OR IMPLIED WARRANTY OF ANY KIND, BY EITHER PROTEMPIS OR ANYONE WHO HAS BEEN INVOLVED IN ITS CREATION, PRODUCTION, INSTALLATION, OR DISTRIBUTION, INCLUDING, BUT NOT LIMITED TO, THE IMPLIED WARRANTIES OF MERCHANTABILITY AND FITNESS FOR A PARTICULAR PURPOSE, TITLE, AND NONINFRINGEMENT. THE STATED EXPRESS WARRANTIES ARE IN LIEU OF ALL OBLIGATIONS OR LIABILITIES ON THE PART OF PROTEMPIS ARISING OUT OF, OR IN CONNECTION WITH, ANY PRODUCT. BECAUSE SOME STATES AND JURISDICTIONS DO NOT ALLOW LIMITATIONS ON DURATION OR THE EXCLUSION OF AN IMPLIED WARRANTY, THE ABOVE LIMITATION MAY NOT APPLY OR FULLY APPLY TO YOU.

Limitation of Liability

PROTEMPIS’ ENTIRE LIABILITY UNDER ANY PROVISION HEREIN SHALL BE LIMITED TO THE AMOUNT PAID BY YOU FOR THE PRODUCT. TO THE MAXIMUM EXTENT PERMITTED BY APPLICABLE LAW, IN NO EVENT SHALL PROTEMPIS OR ITS SUPPLIERS BE LIABLE FOR ANY INDIRECT, SPECIAL, INCIDENTAL, OR CONSEQUENTIAL DAMAGE WHATSOEVER UNDER ANY CIRCUMSTANCE OR LEGAL THEORY RELATING IN ANYWAY TO THE

PRODUCTS, SOFTWARE AND ACCOMPANYING DOCUMENTATION AND MATERIALS, (INCLUDING, WITHOUT LIMITATION, DAMAGES FOR LOSS OF BUSINESS PROFITS, BUSINESS INTERRUPTION, LOSS OF DATA, OR ANY OTHER PECUNIARY LOSS), REGARDLESS OF WHETHER PROTEMPIS HAS BEEN ADVISED OF THE POSSIBILITY OF ANY SUCH

LOSS AND REGARDLESS OF THE COURSE OF DEALING WHICH DEVELOPS OR HAS DEVELOPED BETWEEN YOU AND PROTEMPIS. BECAUSE SOME STATES AND JURISDICTIONS DO NOT ALLOW THE EXCLUSION OR LIMITATION OF LIABILITY FOR CONSEQUENTIAL OR INCIDENTAL DAMAGES, THE ABOVE LIMITATION MAY NOT APPLY TO YOU.

PLEASE NOTE: THE ABOVE PROTEMPIS LIMITED WARRANTY PROVISIONS WILL NOT APPLY TO PRODUCTS PURCHASED IN THOSE JURISDICTIONS (E.G., MEMBER STATES OF THE EUROPEAN ECONOMIC AREA) IN WHICH PRODUCT WARRANTIES ARE THE RESPONSIBILITY OF THE LOCAL PROTEMPIS AUTHORIZED DEALER FROM WHOM THE PRODUCTS ARE ACQUIRED. IN SUCH A CASE, PLEASE CONTACT YOUR LOCAL PROTEMPIS AUTHORIZED DEALER FOR APPLICABLE WARRANTY INFORMATION.

Official Language

THE OFFICIAL LANGUAGE OF THESE TERMS AND CONDITIONS IS ENGLISH. IN THE EVENT OF A CONFLICT BETWEEN ENGLISH AND OTHER LANGUAGE VERSIONS, THE ENGLISH LANGUAGE SHALL CONTROL.

Notices

Class B Statement – Notice to Users. This equipment has been tested and found to comply with the limits for a Class B digital device, pursuant to Part 15 of the FCC rules. These limits are designed to provide reasonable protection against harmful interference in a residential installation. This equipment generates, uses, and can radiate radio frequency energy and, if not installed and used in accordance with the instructions, may cause harmful interference to radio communication. However, there is no guarantee that interference will not occur in a particular installation. If this equipment does cause harmful interference to radio or television reception, which can be determined by turning the equipment off and on, the user is encouraged to try to correct the interference by one or more of the following measures:

- Reorient or relocate the receiving antenna.
- Increase the separation between the equipment and the receiver.
- Connect the equipment into an outlet on a circuit different from that to which the receiver is connected.
- Consult the dealer or an experienced radio/TV technician for help.

Changes and modifications not expressly approved by the manufacturer or registrant of this equipment can void your authority to operate this equipment under Federal Communications Commission rules.

Canada

This Class B digital apparatus complies with Canadian ICES-003.

Cet appareil numérique de la classe B est conforme à la norme NMB-003 du Canada.

Australia and New Zealand

This product conforms with the regulatory requirements of the Australian Communications Authority (ACA) EMC framework, thus satisfying the requirements for C-Tick Marking and sale within Australia and New Zealand.



Europe

This product has been tested and found to comply with the requirements for a Class B device pursuant to European Council Directive 89/336/EEC on EMC, thereby satisfying the requirements for CE Marking and sale within the European Economic Area (EEA). Contains Infineon radio module ROK 104001. These requirements are designed to provide reasonable protection against harmful interference when the equipment is operated in a residential or commercial environment.



Notice to Our European Union Customers

At Protempis, we recognize the importance of minimizing the environmental impacts of our products. We endeavor to meet your needs, not only when you purchase and use our products, but also when you are ready to dispose of them.

That is why Protempis is actively pursuing, and will continue to pursue, the expanded use of environmentally friendly materials in all its products, and why we have established a convenient and environmentally friendly recycling program.

As Protempis makes additional recycling facilities available for your use, we will post their locations and contact information to our website. For product recycling instructions and more information, please go to

Recycling in Europe:

To recycle Protempis WEEE:

Spectra Precision GmbH C/O RCL EHV Ekkersrijt 2066, 5692 BA Son, Netherlands

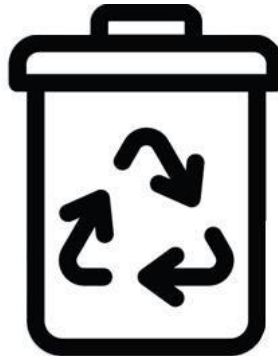

For product recycling instructions and more information, go to www.protempis.com/Compliance

Restriction of Use of Certain Hazardous Substances in Electrical and Electronic Equipment (RoHS)

As of July 1, 2006, the Product is compliant in all material respects with DIRECTIVE 2002/95/EC OF THE EUROPEAN PARLIAMENT AND OF THE COUNCIL of 27 January 2003 on the restriction of the use of certain hazardous substances in electrical and electronic equipment (RoHS Directive) and Amendment 2005/618/EC filed under C(2005) 3143, with exemptions for lead in solder pursuant to Paragraph 7 of the Annex to the RoHS Directive applied. The foregoing is limited to Product placed on the market in the Member States of the European Union on or after 1 July 2006. Protempis has relied on representations made by its suppliers in certifying this Product as RoHS compliant.

Declaration of Conformity

We, Protempis,
United States of America

declare under sole responsibility that the product:
ThunderBolt E GPS Disciplined Clock
complies with Part 15 of FCC Rules.

Operation is subject to the following two conditions:
(1) this device may not cause harmful interference, and
(2) this device must accept any interference received, including interference that may cause undesired operation.

Safety Information

Warnings and Cautions

An absence of specific alerts does not mean that there are no safety risks involved.

Always follow the instructions that accompany a Warning or Caution. The information they provide is intended to minimize the risk of personal injury and/or damage to the equipment. In particular, observe safety instructions that are presented in the following formats:



WARNING – A Warning alerts you to a likely risk of serious injury to your person and/or damage to the equipment.



CAUTION – A Caution alerts you to a possible risk of damage to the equipment and/or loss of data.

Operation and storage



WARNING – Operating or storing the ThunderBolt E GPS disciplined clock outside the specified temperature range can damage it. For more information, see the product specifications on the data sheet.

Routing any cable



CAUTION – Be careful not to damage the cable. Take care to avoid sharp bends or kinks in the cable, hot surfaces (for example, exhaust manifolds or stacks), rotating or reciprocating equipment, sharp or abrasive surfaces, door and window jambs, and corrosive fluids or gases.

AC adaptor safety

An international adaptor kit is provided with the ThunderBolt E GPS disciplined clock.



WARNING – Using an incorrect AC adaptor can damage your product and may void your warranty. To use AC adaptors safely:

- Use only the AC adaptor intended for the ThunderBolt E. Using any other AC adaptor can damage your product and may void your warranty.
 - Do not use the AC adaptor with any other product.
 - Make certain that the input voltage on the adaptor matches the voltage and frequency in your location.
 - Make certain that the adaptor has prongs compatible with your outlets.
 - AC adaptors are designed for indoor use only. Avoid using the AC adaptor in wet outdoor areas.
 - Unplug the AC adaptor from power when not in use.
 - Do not short the output connector.
 - There are no user-serviceable parts in this product.
 - Should damage to the AC adaptor occur, replace it with a new Protempis AC adaptor.
-

Lightning and ground faults



WARNING – If the antenna is mounted outside, you must take appropriate safety measures against lightning and ground faults. The required protection measures vary by location and application and are outside the scope of this document. Refer to local safety codes and regulations.

Contents

	Safety Information	5
	Warnings and Cautions	5
	Operation and storage	5
	Routing any cable	5
	AC adaptor safety	6
	Lightning and ground faults	6
1	Introduction	9
	Operation	10
	Features	10
	Hardware features	10
	Interface protocols	10
	Standard timing software features	11
	Starter kit	11
	Use and care	11
	Technical assistance	11
2	Setting up and Running the ThunderBolt E	13
	System requirements	14
	Hardware	14
	Computer	14
	System software	14
	Installing and using the software	15
	Protempis GPS Studio software	15
	TSIP	19
	ThunderBolt E starter kit	22
	Setting up the ThunderBolt E clock	23
3	Hardware Integration	25
	ThunderBolt E system architecture	26
	ThunderBolt E module	26
	Environmental specifications	26
	Performance specifications	27
	Physical characteristics	27
	Bullet antenna specifications	29
	Physical characteristics	29
	Environmental specifications	29
	Antenna cable	29
	I/O connector pin-out	31
	Power supply and connector	31
	Alarm conditions	31

- 4 Firmware Integration 33**
 - Firmware configuration 34
 - Firmware upgrades 34
 - Firmware features 34

- A Protempis Standard Interface Protocol. 35**
 - Introduction 36
 - Interface scope. 36
 - Automatic output packets 36
 - Customizing operations parameters 37
 - Packets output at power-up 39
 - Command packets: User to ThunderBolt E 39
 - Report packets: ThunderBolt E to User 40
 - Packet structure 42
 - Packet descriptions 43
 - Packet descriptions used in run mode 43
 - TSIP Superpackets 66

- B Calibration and Traceability 87**
 - Traceability of ThunderBolt GPS-DO clock to national standards 88
 - Chain of authority 90

Introduction

In this chapter:

- [Operation](#)
- [Features](#)
- [Starter kit](#)
- [Use and care](#)
- [Technical assistance](#)

Welcome to the *Protempis ThunderBolt E GPS Disciplined Clock User Guide*. The user guide describes how to install, set up, and use the Protempis® ThunderBolt® E GPS disciplined clock (“ThunderBolt E”).

The ThunderBolt E integrates proven GPS technology into a rugged, self-contained unit. It provides an accurate one pulse-per-second (PPS) and stable 10 MHz frequency output source for output to synchronize and time broadband wireless, cellular base stations, Time Difference of Arrival (TDOA) applications, and many other Supervisory Control and Data Acquisition (SCADA) applications.

The ThunderBolt E can also be used as a reference source for use in laboratories, manufacturing, testing, and research facilities. In calibration laboratories, the ThunderBolt E is fully traceable to national standards through the atomic clocks carried on GPS satellites—this eliminates the calibration cycle required with more traditional sources. The ThunderBolt E can be fully integrated into laboratory operations and meets the requirements of laboratory accreditation organizations and ISO /IEC 17025.

For general information on GPS technology, go to <http://www.Protempis.com/gps/index.shtml>.

For more information on Protempis timing synchronization products go to <http://www.Protempis.com/timing/>.

Operation

The ThunderBolt E GPS disciplined clock provides time and frequency through a 12-channel GPS receiver and a high-quality ovenized quartz oscillator integrated onto a single printed circuit board. Tightly integrating GPS into the clock design eliminates the need for a separate GPS receiver. This results in better reliability, a smaller size, and a cost advantage.

The board in the ThunderBolt E consists of one board with GPS and a 24 V power supply regulator. This power supply regulator ensures clean, robust power to the GPS. The board can support several different oscillators for applications having stringent holdover requirements.

The ThunderBolt E is ready to use out of the box for most applications. When a +24 VDC power source is applied, the ThunderBolt E will begin to track satellites—four satellites are required to begin the self-survey process. At the same time the oscillator will come up to operating temperature and stabilize, outputting the 1 PPS and reference frequency.

To get the most from your time reference, you can customize the ThunderBolt E using the Protempis binary interface, TSIP (Protempis Standard Interface Protocol). For more information, see [Appendix A, Time Standard Interface Protocol](#).

Features

Hardware features

- A single printed circuit board containing
 - A quality ovenized oscillator
 - A 12-channel GPS receiver
 - Control circuitry
- Easy integration with the Protempis Bullet™ antenna
- Easy calibration for different cable lengths
- Output
 - 10 MHz reference signal output via BNC connector
 - 1 PPS output with an Over-determined solution synchronized to GPS or UTC time

Interface protocols

The ThunderBolt E uses the Time Standard Interface Protocol (TSIP). This is a binary packet protocol that allows the system designer maximum configuration control over the GPS receiver for optimum performance in timing applications. TSIP

supports multiple commands and their associated response packets for use in configuring the ThunderBolt E to meet your requirements. See [Appendix A, Time Standard Interface Protocol](#).

Standard timing software features

- Automatic self-survey
- Signal integrity through a Time-Receiver Autonomous Integrity Monitor (T-RAIM) algorithm

Starter kit

The ThunderBolt E Starter Kit contains all the components required for evaluating and engineering purposes and is quick and easy to install, with your +24 V power source. It is a high-performance, cost-effective reference time source that uses GPS technology to precisely synchronize computers, servers, and Internet applications. See [Setting up the ThunderBolt E clock, page 23](#).

Use and care

The ThunderBolt E is a high-precision electronic instrument and should be treated with reasonable care.

If a problem arises with the unit, an amber indication appears in the monitor program under *Minor Alarms*. Contact Protempis for technical direction and repair.

Note – Not every Minor Alarm indicates a problem.

C

CAUTION – There are no user-serviceable parts inside the ThunderBolt E and any modification to the unit by the user voids the warranty.

Technical assistance

If you have a problem and cannot find the information you need in the product documentation, contact your Protempis Sales representative or email support@Protempis.com.

Setting up and Running the ThunderBolt E

In this chapter:

- [System requirements](#)
- [Installing and using the software](#)
- [ThunderBolt E starter kit](#)
- [Setting up the ThunderBolt E clock](#)

Protempis recommends that you install the Protempis GPS Studio software before setting up the ThunderBolt E GPS disciplined clock. This enables you to monitor the acquisition of satellites once you start up the GPS disciplined clock.

Various kits are available for testing, evaluation, and engineering purposes. This chapter describes the components of the starter kit, and how to set it up. Other kits are similar.

The hardware integration is described in [Chapter 3, Hardware Integration](#).

System requirements

Hardware

- For evaluation or engineering purposes:
 - The Protempis ThunderBolt E GPS disciplined clock starter kit, see [page 22](#).
 - User-provided connectors and extension cords to connect the ThunderBolt E module to the computer, antenna interface, and other devices as required.
- For permanent installation:
 - ThunderBolt E GPS disciplined clock module
 - Protempis Bullet antenna
 - 75–100 feet of approved cable (RG-6) with two M-M TNC connectors

Note – 50 Ω or 75 Ω RF cable can be used. Typical impedance mismatch will reflect only 0.5 dB of additional attenuation at 1575.42 MHz. See also [Cable delay compensation, page 19](#)

- +24 VDC power supply
- User-provided equipment to analyze the 10 MHz output frequency and the 1 PPS accuracy, and a BNC connector to connect them to the ThunderBolt E module.
- User-provided connectors and extension cords to connect the ThunderBolt E module to the computer, antenna interface, and other devices as required.

Computer

- An office computer running a version of the Microsoft® Windows® operating system (Windows NT or later)

System software

- Protempis GPS Studio software. The software is used to monitor the GPS performance of the ThunderBolt E and to change its settings. The software is compatible with the Windows 7, Windows Vista®, Windows XP (with service pack 2) or Windows 2000 (with service pack 4) operating systems. See [Protempis GPS Studio software, page 15](#).
- Time Standard Interface Protocol (TSIP). This consists of command packets and report packets. See [Appendix A, Protempis Standard Interface Protocol](#).

Installing and using the software

All software programs for the ThunderBolt E are available online from the Protempis website at www.protempis.com. These programs enable you to monitor the ThunderBolt E and change its configuration settings.

B **Tip** – Install and set up the monitor program before turning on the ThunderBolt E—this allows you to observe the timing process, from start up to fully functioning.

Protempis GPS Studio software

C **CAUTION** – Use only the Protempis GPS Studio software with this product. Previous versions may not be compatible.

To install the Protempis GPS Studio application from the website:

1. Go to <http://www.protempis.com/support> and then select *ThunderBolt E GPS Disciplined Clock*.
2. Click *Protempis GPS Studio Application* and then download the ProtempisStudio.exe file to the computer's hard drive.

- To run the application, double-click the file. The *Protempis GPS Studio* screen appears:

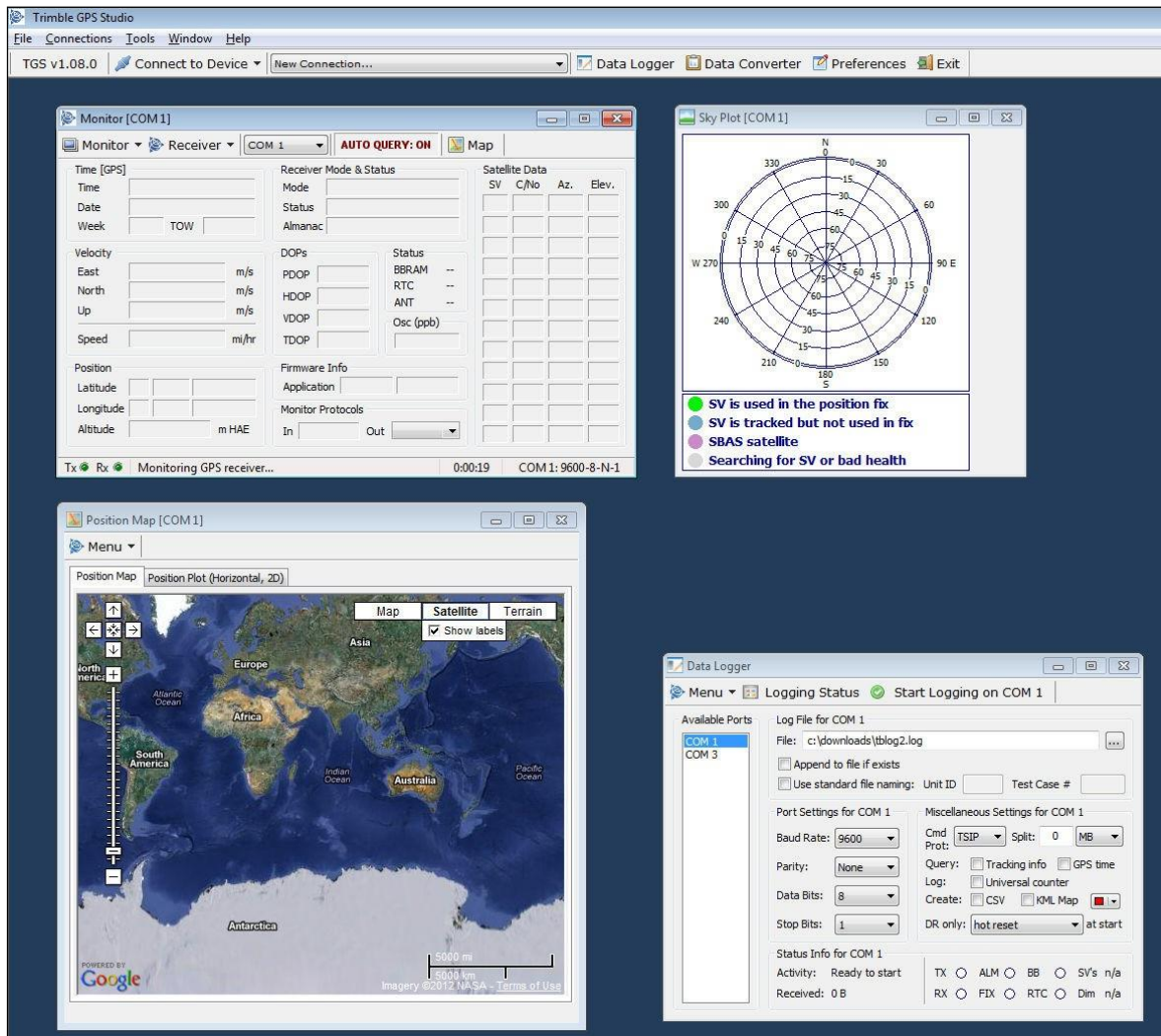

The Protempis GPS Studio software is designed to work with several different products and at this time has no way to identify the ThunderBolt E.

- Set up the ThunderBolt E, see [page 23](#). When you apply power, the Protempis GPS Studio software detects and communicates with the ThunderBolt E clock. The first indication of this is that the *Timing Receiver Status and Control* screen opens, after which the title of the *Monitor* screen changes to *ThunderBolt E Monitor*.

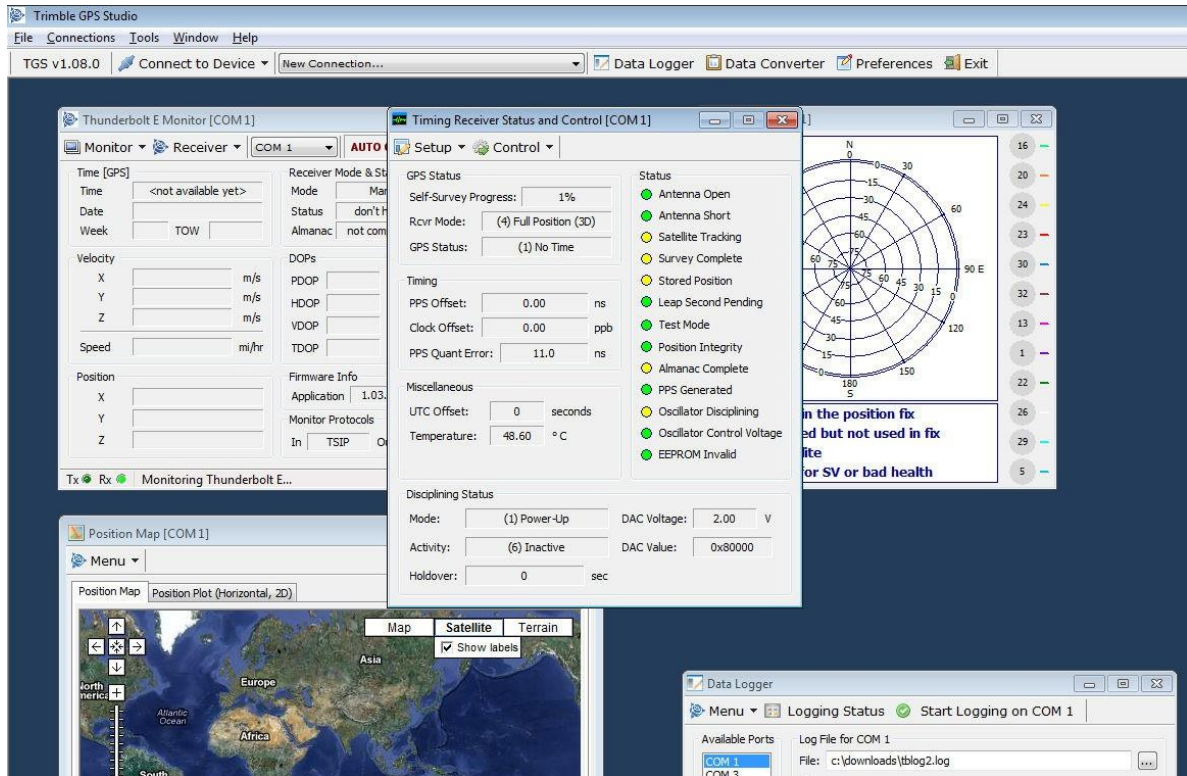

As the ThunderBolt E clock stabilizes, status indicators on the *Timing Receiver Status and Control* screen turn green and the *ThunderBolt E Monitor* screen displays the current condition of the clock.

Note – Only some of the status alarms indicate problems; others, such as *Leap Second Pending*, just provide information.

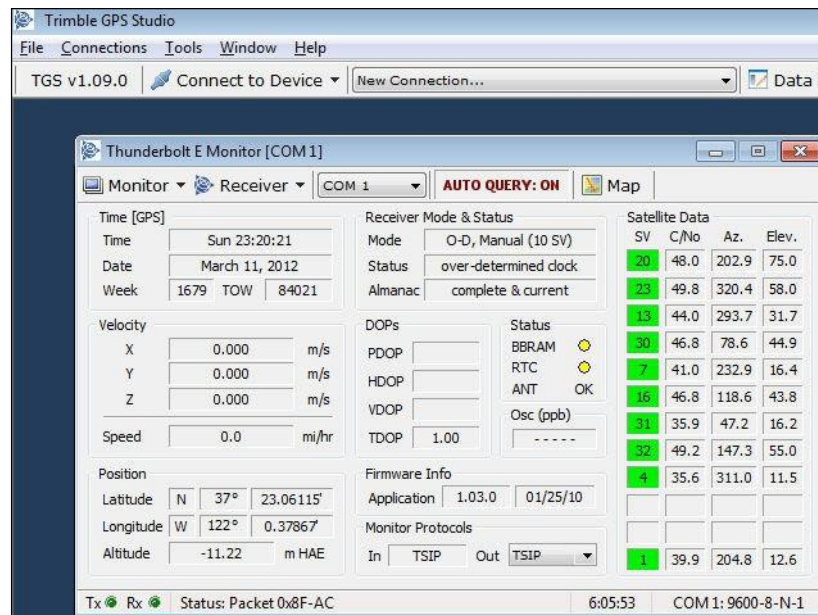

The ThunderBolt E clock GPS receiver automatically begins with a self-survey to establish position. Once the self-survey is complete, the following information appears in the software:

- Position
- Time
- Satellites tracked
- GPS receiver status

The position is stored in the ThunderBolt E memory and the receiver switches to over-determined clock mode. To display the position in latitude and longitude, right-click in the *Position* field and then select the appropriate format.

Note – The ThunderBolt E clock does not provide position information in X,Y,Z coordinates.

Note – The receiver sends a health report every few seconds even if satellites are not being tracked.

5. The bar at the bottom of the *ThunderBolt E Monitor* screen shows the status of the communications between the Protempis GPS Studio application and the ThunderBolt E clock:

- Transmit (Tx) and Receive (Rx) indicators and packet identification appear on the left of the bar.
- Communications port settings appear on the right.
- Elapsed time since startup appears in the middle.

Data fields

If the Protempis GPS Studio program displays a question mark (?) in a data field, the receiver has not reported a status for this field. If the question mark stays in place, the GPS module may not be communicating with the computer. Check the interface cable connections and verify that the serial port selection and settings are set to 9600 baud, no parity, 8-bit, and 1 stop/start bit.

Receiver COM port settings

Packet 0xBC sets the ThunderBolt E GPS port characteristics. To change the receiver port and then set or request the Input/Output baud rate, data bits, parity, stop bits, and flow control parameters, select *Configure / Receiver Configuration / Port Configuration dialog*.

TSIP

The Time Standard Interface Protocol (TSIP) consists of command packets and report packets. The basic features that are described here include some of the more commonly used commands and reports. For a complete description of TSIP, see [Appendix A, Time Standard Interface Protocol](#)

Note – You do not need the packet number when you use the Windows Control Program.

Cable delay compensation

Packet 0x8E-4A enables you to delay or advance the 1 PPS. This may be required to compensate for a long cable run. Negative values advance the 1 PPS and compensate for cable delay. The 10 MHz and 1 PPS output will remain synchronized.

The units are in seconds and can be entered in decimal format or in scientific notation. For example, a 50 ns delay for the 1 PPS signal may be entered as 0.00000005, $50e^{-9}$, or $50e^{-8}$, all representing the same value in seconds.

For cable compensation, the 1 PPS signal needs to be advanced so that the numbers that are entered are negative. For example, enter a 20 ns advance as -0.00000002 or as $-20e^{-9}$.

Cable delays vary by type of construction and the materials used. For the cable supplied in the kit, use a value of 5.05 ns per meter (1.54 ns per foot). For other cables, see the manufacturers specifications for the cable.

Note – The factory default is zero.

Timing information

Packet 0x8F-AB (primary timing information) and packet 0x8F-AC (supplemental timing information) contain most of the information that you need to monitor the ThunderBolt E. In the default configuration, these packets are broadcast once per second.

Elevation Mask

This is the minimum elevation angle for satellites that is used in a solution output by the receiver (see [Command Packet 0xBB: Set Receiver Configuration, page 64](#)). Satellites that are near the horizon are typically more difficult to track due to signal attenuation, and are generally less accurate due to higher variability in the ionospheric and tropospheric corruption of the signal. When there are no obstructions, the receiver can generally track a satellite to near the horizon. However, when this mask is set too low, the receiver may experience frequent constellation switching due to low elevation satellites being obscured.

Frequent constellation switching is associated with undesirable timing jumps. If the mask setting is too high, it may reject good satellites. The current mask is set to ten degrees and provides a reasonable trade-off between the benefits and drawbacks.

Signal Level Mask

This mask defines the minimum signal strength for a satellite used in a solution. There is some internal hysteresis on this threshold that allows brief excursions below the threshold if lock is maintained and the signal was previously above the mask. The factory default mask is zero. High accuracy users may use a slightly higher mask of 6.0 to 8.0, since weaker measurements may be slightly noisier and are often caused by reflected signals that provide erroneous ranges.

***Note** – A level of hysteresis in the signal level mask is allowed in the core operating software. The hysteresis allows the receiver to continue using satellite signals that fall slightly below the mask and prevents the receiver from incorporating a new signal until the signal level slightly exceeds the mask. This feature minimizes constellation changes caused by temporary fluctuations in signal levels.*

Reference position

When the antenna is connected and power is applied, the GPS module generates a precise PPS signal, a 10 MHz frequency output, and several miscellaneous periodic outputs. It calculates a clock-only solution from the GPS data. In clock-only (position-hold) mode, a static reference position is established and all of the available satellites are used to solve for a time solution. The reference position may be determined automatically by the ThunderBolt E (self-survey) or may be uploaded to the ThunderBolt E by the host, if the position is known. The accuracy and integrity of the timing solution is highly dependent on the accuracy of the reference position.

If the host has not uploaded a reference position, or if the module has been moved more than one to two kilometers since its last position, the GPS module automatically conducts a position survey at startup. By default, the GPS module averages 2000 position fixes before entering the clock-only mode. The host system can adjust the survey period using packet 0x8E-A6. While the GPS module is performing its survey, the accuracy of the timing outputs will be degraded.

Uploading a reference position

To upload an accurate reference position, use packet 0x31 ([Command Packet 0x31: Accurate Initial Position \(XYZ Cartesian ECEF\), page 46](#)), or packet 0x32 ([Command Packet 0x32: Accurate Initial Position \(Latitude, Longitude, Altitude\), page 46](#)): The reference position is stored in EEPROM (Electrically Erasable Programmable Read-Only Memory) and is retained during power loss. When a reference position is stored in EEPROM, the GPS module bypasses the position survey procedure and enters clock-only mode. If you move the antenna, you must send packet 0x8E-45 to clear the position stored in EEPROM: The GPS module then initiates a self-survey, unless the host uploads a new position using packet 0x31 or packet 0x32.

To store the reference position from the self-survey procedure in the EEPROM, send packet 0x8E-4C to the receiver. Alternatively, you can configure the ThunderBolt E to automatically save the position using packet 0x8E-A9.

ThunderBolt E starter kit



Note – The ThunderBolt Lab Kit has an additional power cable (unterminated) to allow you to attach a laboratory power supply or for wiring the unit into a test fixture.

Setting up the ThunderBolt E clock

Note – You can either set up the kit temporarily for testing or evaluation purposes, or embed it permanently into your system. The procedures are similar.



WARNING – If the antenna is mounted outside, you must take appropriate safety measures against lightning and ground faults. The required protection measures vary by location and application and are outside the scope of this document. Refer to local safety codes and regulations.

1. Connect the male connector of the antenna cable to the Bullet antenna.
2. Place the antenna so that it has the fullest possible view of the sky.

To mount the antenna permanently, place it on a high point, such as a roof. Make sure that it is placed away from obstructions, such as neighboring buildings that may block its view of the sky, or overhanging objects, such as trees or towers.

Note – If required, you can mount the antenna on a 1" marine pipe with 14 threads per inch (1-14 UNS per ANSI / ASME B1.1) or on a 3/4" plumbers pipe (3/4 NTP per ANSI / ASME B1.20.1).

3. Route the antenna cable to the receiver.



CAUTION – Be careful not to damage the cable. Take care to avoid sharp bends or kinks in the cable, hot surfaces (for example, exhaust manifolds or stacks), rotating or reciprocating equipment, sharp or abrasive surfaces, door and window jambs, and corrosive fluids or gases.

4. Secure the cable using tie-wraps, starting at the antenna and allowing for a drip loop, and working towards the ThunderBolt E module. Ensure that the cable is secured at points close to the antenna and the ThunderBolt E module.

Note – Additional protection (for example, heat-shrink tubing) may be required to protect the cable jacket at points where the opening is rough or sharp, such as where it enters or exits bulkheads.

5. If required, cut the cable to the required length and then terminate it with the correct connectors. Make sure that:
 - There is enough slack for a service loop near the antenna to allow for disconnection, for moisture to drip away from the connection, and for normal movements of the antenna.
 - All contact surfaces are clean and firm before crimping.
6. If cut, re-attach the male TNC connector to the cut end.
7. Connect the standard RS-232 interface cable directly to the office computer.

Note – The TSIP serial port is set at 9600 baud, no parity, 8-bit, 1 stop/start bit.

8. Connect the +24 V DC power input (part of the Power and I/O interface cable assembly) to the power converter.

9. Use the adaptor cable to connect the power converter to the main power and then switch on the mains power.

After you turn on the ThunderBolt E, it takes approximately 5 minutes for the ovenized oscillator to warm up. During this time, it will begin acquiring satellites in less than 60 seconds, as shown in the Protempis GPS Studio software on your computer.

Once the ThunderBolt E has warmed up and acquired satellites it performs a self-survey: If at least one satellite is currently available, it will output 1 PPS and 10 MHz data to the Protempis GPS Studio software, see [page 15](#). The complete process can take an hour. Overall performance will improve after several days of continuous operation.

1 PPS and 10 MHz is not synchronized with GPS until the unit enters Over-Determined Clock mode.

Hardware Integration

In this chapter:

- [ThunderBolt E system architecture](#)
- [ThunderBolt E module](#)
- [Bullet antenna specifications](#)
- [Antenna cable](#)
- [I/O connector pin-out](#)
- [Power supply and connector](#)

The setup procedures for the ThunderBolt E GPS disciplined clock are described in [Setting up the ThunderBolt E clock, page 23](#). This chapter describes the hardware components, to assist you when you integrate the ThunderBolt E into a system.

ThunderBolt E system architecture

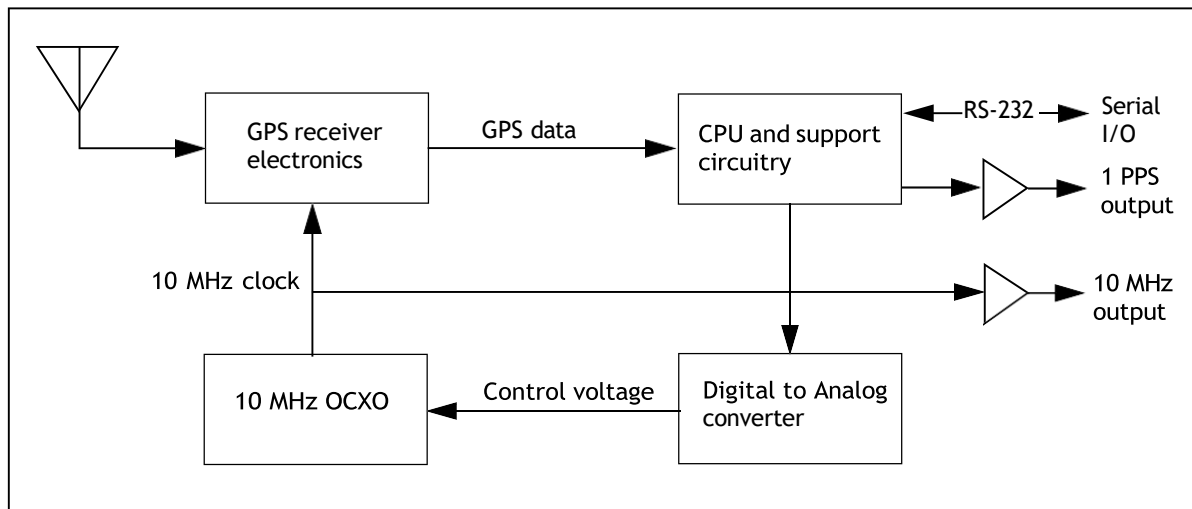

ThunderBolt E module

The ThunderBolt E consists of a board mounted inside an aluminum case. The board contains the parts for power regulation, a GPS receiver, an oscillator, and disciplining circuitry.

Environmental specifications

Operating temperature	-20 °C to +75 °C (-4 °F to 167 °F)
Storage temperature	-40 °C to +85 °C (-40 °F to 185 °F)
Operating humidity	95% non-condensing
Maximum altitude	18,000 meter (11.2 miles)

Performance specifications

General	L1 frequency, CA/code (SPS), 12-channel continuous tracking receiver
Update rate	1 Hz
PPS accuracy	UTC 15 nanoseconds (one sigma)
10 MHz accuracy	1.16×10^{-12} (one day average)
Harmonic level	-40 dBc max
Spurious	-70 dBc max
Phase noise	10 Hz -115 dBc/Hz 100 Hz - 130 dBc/Hz 1 kHz -135 dBc/Hz 10 kHz -145 dBc/Hz 100 kHz -145 dBc/Hz
Holdover	Some customers, such as CDMA manufacturers, have historically mandated tighter holdover requirements than specified. For increased holdover performance, please contact your local Protempis representative.

Physical characteristics

Power consumption	12 W cold 8 W steady state
Antenna supply voltage	5 V \pm 10%
Dimensions	127 mm (length) x 102 mm (width) x 40 mm (height) (5" x 4" x 2")
Weight	0.285 kg (0.628 lb)
Mounting	6 mounting holes for M3 screws. Maximum depth 12 mm.

The module dimensions of the ThunderBolt E are shown overleaf.

C

CAUTION – When permanently mounting the ThunderBolt E onto a plate, you must consider the length of the screw and the thickness of plate so that you do not protrude into the ThunderBolt E and potentially damage the electronics.

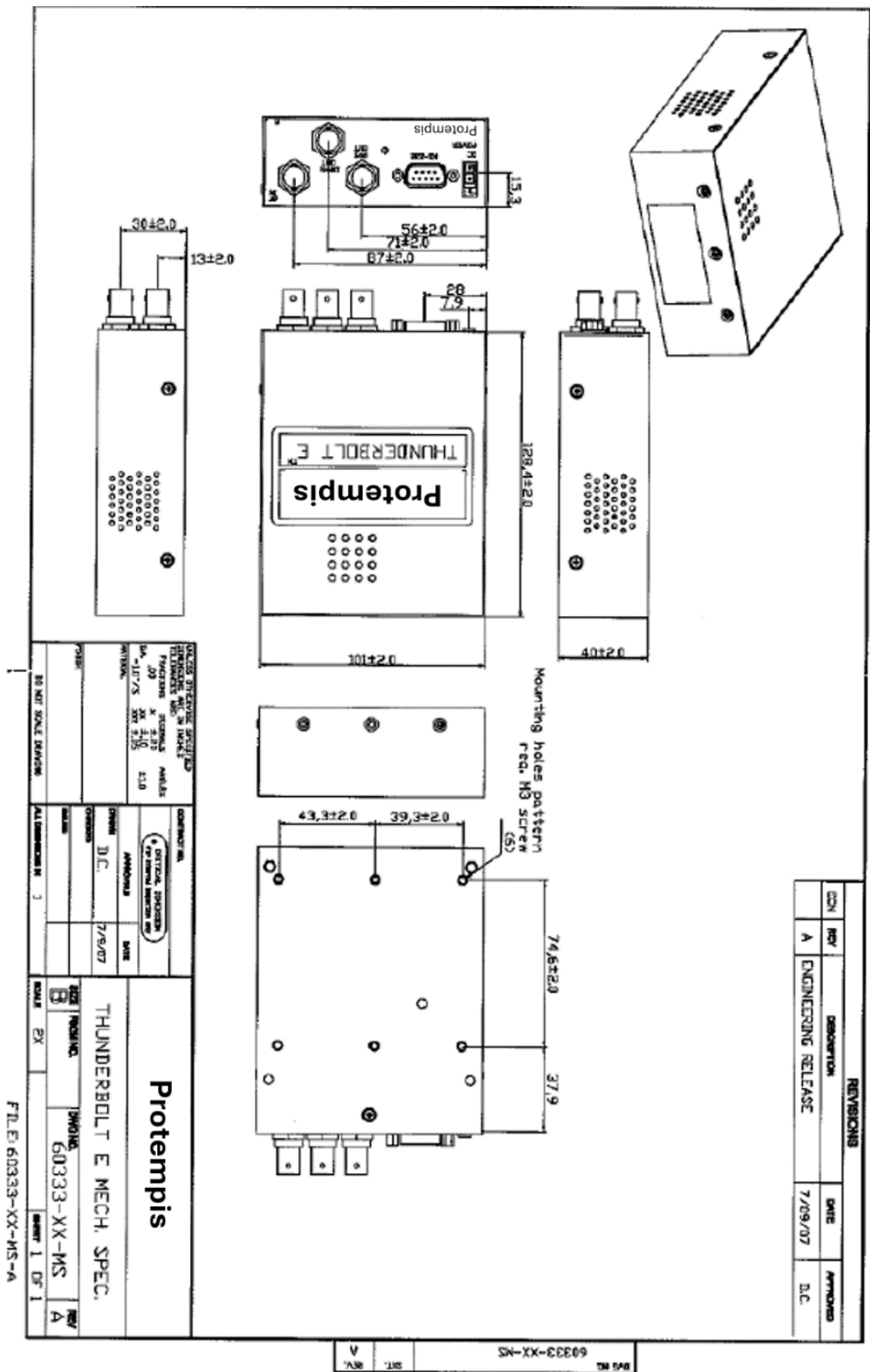

Figure 3.1 ThunderBolt E mechanical specification

Bullet antenna specifications

To download full specifications of the Bullet antenna, as well as ordering information, please go to the Protempis website.

Physical characteristics

Dimensions	77.5 mm diameter x 66.2 mm height (3.05" x 2.61")
Bullet enclosure	Textured, off-white plastic
Antenna weight	170 grams (6 oz)
Connector	F-type or TNC
Mount	You can mount the antenna on a 1" marine pipe with 14 threads per inch (1-14 UNS per ANSI / ASME B1.1) or on a ¾" plumbers pipe (¾ NTP per ANSI / ASME B1.20.1)"

Note – The Bullet III mounting thread is a ¾" NPT thread, dimensions in accordance with ANSI/ASME B1.20.1. It is compatible with tapered threads in accordance with DIN EN 10226 (which is the same as ISO 7/1, DIN 2999, BSP 21, JIS B0203). It is not compatible with straight threads in accordance with ISO 228/1.

Environmental specifications

Operating temperature	-40 °C to +85 °C (-40 °F to 185 °F)
Storage temperature	-40 °C to +100 °C (-40 °F to 212 °F)
Vibration	0.04g ² /Hz 10 Hz to 500 Hz 0.03g ² /Hz 500 Hz to 850 Hz 0.02g ² /Hz 850 Hz to 1200 Hz
Shock	50 g vertical, 30 g all axes
Humidity	Mil-STD-810E
Salt Fog	Mil. Std. 202F, Method 101D Condition B
Waterproof	Submersion to 1 meter

Antenna cable

Protempis includes an RG-6 cable in the starter kit to connect the ThunderBolt E and the Bullet antenna. This cable type is widely available.

Note – The ThunderBolt E and the Bullet antenna are compatible with either 50 Ω or 75 Ω cable. Compared to most 50 Ω cable, 75 Ω cable provides superior transmission for the 1.5 GHz GPS signal and a better quality cable for the price. Mismatched impedance is not a problem.

Note – RG-6 cable is lower loss than RG-59 and can be used when trying to maximize a cable run without the use of in-line amplifiers.

The Bullet antenna has greater than 28 dB gain and “best case” noise figure of 3 dB. The ThunderBolt E has less than an 8 dB noise figure. The system can therefore “tolerate” 18 dB of cable loss for less than 1 dB degradation in performance.

In cases where the distance between the Bullet and the ThunderBolt E is excessive (for example when the loss exceeds 18 dB), an inline amplifier is necessary.

The following table shows the loss relationships:

Cable type	dB / 100 ft	dB / 100 meter	Max length for 18 dB loss at 1575 MHz (feet / meter)
RG-6	12	40	150/45
RG8 (and 8/U)	9.6	31	185/58
RG-8X	16.8	55	107/33
RG-58	19.6	64	92/28
RG-59	14.7	48.2	122/37
LMR-400	5.3	17.2	340/105
LMR-600	3.4	11.2	530/161

In cases where the run length is such that the loss exceeds 18 dB, an inline amplifier (LNA) with the following specifications is required:

- Place the LNA at a point in the coaxial line so that the loss between the Bullet antenna and the LNA does not exceed 18 dB.
- The noise figure of the LNA must be 3 dB or less. The gain of the LNA should be at least 3 dB greater than the cable loss between the output of the inline LNA and the ThunderBolt E input. Protempis recommends that a filtered LNA is used to reduce overload by out-of-band signals. (Filtered LNAs are made by GPS Networking.)

For example, if you choose an RG-6 cable with 40 dB/100 meter loss, and the required run-length is 90 meters, the total loss for this run would be $(0.9)(40 \text{ dB}/100 \text{ meters}) = 36 \text{ dB}$. This exceeds 18 dB and means that you need to use an inline amplifier.

However, if you select an LMR-400 or LMR-600 cable, you would *not* need an inline amplifier.

- The noise figure of the inline amplifier must be 3 dB or less. The gain of this LNA would be 21 dB (18 dB loss precedes LNA, 18 dB of loss follows LNA, and drives requirement for $18 + 3 = 21 \text{ dB}$ gain for the LNA).

I/O connector pin-out

The RS-232 serial port uses a DB-9 connector. This configuration supports connections to the RS-232 serial port on a computer. The pinout functions are as follows.

Pin	Function	Signal / Protocol
1	Not used	
2	TxD	Transmit out/RS-232
3	RxD	Receive in RS-232
4	Not used	
5	Signal ground	
6	Not used	
7	Not used	
8	Not used	
9	Not used	

Power supply and connector

The ThunderBolt E starter kit includes a 24 V power supply regulator. The module requires a locally supplied +24 V DC. Power consumption is 15 Watts cold and 10 Watts steady state.

Use the following to connect to the ThunderBolt E power input:

MOLEX part number	Item	Quantity
MLX 39-01-2020	Connector plug	1
MLX 44476-112	Contact pin	2

Alarm conditions

Power supply	Alarm conditions			Bicolor LED
	Initialization Warm-up Tracked-fast OXCO GPS	Antenna	Holdover	
On	0	0	0	Green
On	1	0	1	Red
On	0	1	1	Red (blinking)
On	1	0	0	Green (blinking)
On	1	1	0	Red/Green (blinking)
Off/Failure	x	x	x	Blank

0: No alarm condition or masked alarm condition

1: Active alarm condition

Firmware Integration

In this chapter:

- [Firmware configuration](#)
- [Firmware upgrades](#)
- [Firmware features](#)

This section will help a developer to understand the structure of the ThunderBolt E firmware.

Firmware configuration

The ThunderBolt E maintains its configuration parameters in a non-volatile memory device (EEPROM). In the EEPROM, related configuration parameters are grouped together and stored in an area known as a “segment”. There are seven user-configurable segments. Immediately after a reset, the ThunderBolt E reads the segment contents from the EEPROM, stores a working copy in RAM and then configures itself based on the working copy of the segments. You can do the following:

- To modify the contents of the working copy, use the “Set” command packets.
- To read the working copies of the segments, issue the “Request” command packet and wait for the “Report” packet response.

When you alter a parameter, the ThunderBolt E reconfigures, but the contents of the EEPROM are not changed automatically.

The ThunderBolt E has two command packets that can control the contents of the segments stored in EEPROM:

- Command packet 0x8E-4C enables you to save the contents of any or all working copies of the segments to EEPROM.
- Command packet 0x8E-45 enables you to set the contents of any or all the segments stored in EEPROM to the factory default.

Firmware upgrades

When firmware upgrades are available, Protempis will provide software and instructions for installation on the Protempis website at www.protempis.com.

Firmware features

The firmware includes:

- Kalman filtering for better performance during holdover.
- 1 PPS calibrated to the USNO master clock for a more accurate “out of box” performance.
- New position integrity monitor that warns you if the receiver is using an incorrect position.
- User-selectable recovery algorithm that enables you to define how the clock will recover from holdover.
- Silent TSIP options that enable you to choose which packets, if any, are to be reported.

Time Standard Interface Protocol

In this appendix:

- [Introduction](#)
- [Packet structure](#)
- [Packet descriptions](#)

The Time Standard Interface Protocol (TSIP) may be characterized as a set of data packets used to transmit information to and receive information from a Protempis GPS receiver. Protempis products commonly support a version of TSIP which is customized to the attributes of the product. This appendix describes the ThunderBolt E customization.

Introduction

TSIP is a powerful and compact interface protocol which has been designed to allow the system developer a great deal of flexibility in interfacing to a Protempis product. Many TSIP data packets are common to all products which use TSIP. An example would be a single precision position output packet. Other packets may be unique to a product. Custom packets are only used in the products for which they have been created.

Note – This appendix has been generated and reviewed with care, however, Protempis is always grateful to receive reports of any errors in either products or documentation.

Interface scope

ThunderBolt E has one configurable serial I/O communication port, which is a bi-directional control and data port using a Protempis Standard Interface Protocol (TSIP). The data I/O port characteristics and other options are user programmable and stored in non-volatile storage (NVS) memory.

The TSIP protocol is based on the transmission of packets of information between the user equipment and the GPS receiver. Each packet includes an identification code that identifies the meaning and format of the data that follows. Each packet begins and ends with control characters.

Automatic output packets

ThunderBolt E is configured to automatically output the 0x8F-AB and 0x8F-AC packets. For most system implementations these output packets provide all of the information required for operation including time, position, GPS status, and health. The following packets can be broadcast if enabled with packet 0x8E-A5 and 0x35. By default, only packets 0x8F-AB and 0x8F-AC are enabled for output.

Broadcast output packets

Broadcast Packet ID	Description	Masking Packet ID	Request Packet ID	When Sent
0x42	Position XYZ (ECEF), single precision	0x35 and 0x8E-A5 (bit 6)	0x37	When a position fix is computed
0x43	Velocity XYZ, single precision	0x35 and 0x8E-A5 (bit 6)	0x37	When a position fix is computed
0x47	Signal Levels	0x8E-A5 (bit 6)	0x27	Once per second
0x4A	Position LLA, single precision	0x35 and 0x8E-A5 (bit 6)	0x37	When a position fix is computed
0x56	Velocity ENU, single precision	0x35 and 0x8E-A5 (bit 6)	0x37	When a position fix is computed
0x5A	Raw Measurements	0x35 and 0x8E-A5 (bit 6)	0x3A	When new measurements are available
0x6D	Satellite list, DOPS, mode	0x8E-A5 (bit 6)	0x24	Once per second

Broadcast Packet ID	Description	Masking Packet ID	Request Packet ID	When Sent
0x83	Position XYZ (ECEF), double precision	0x35 and 0x8E-A5 (bit 6)	0x37	When a position fix is computed
0x84	Position LLA, double precision	0x35 and 0x8E-A5 (bit 6)	0x37	When a position fix is computed
0x8F-AB	Primary timing packet	0x8E-A5 (bit 0)	0x8E-AB	Once per second
0x8F-AC	Secondary timing packet	0x8E-A5 (bit 2)	0x8E-AC	Once per second

Customizing operations parameters

ThunderBolt E provides a number of user-configurable parameters that enables the user to customize its operation. These parameters are stored in NVS memory to be retained during loss of power and through resets. At reset or power up, ThunderBolt E configures itself based on the parameters stored in NVS. The user can change the values of these parameters to achieve the desired operation using a variety of TSIP packets. ThunderBolt E configures itself based upon the new parameters immediately, but the new parameter is not automatically saved to NVS. The user must direct ThunderBolt E to save the parameters to NVS. This is done by sending packet 0x8E-4C with the ID of the segment containing the changed parameter. Users can also direct ThunderBolt E to set the parameter values for a specified segment to their factory defaults by sending packet 0x8E-45.

To customize ThunderBolt E output:

1. Set up ThunderBolt E using TSIP commands until the required operation is achieved.
2. Use command 0x8E-4C to store the settings in non-volatile memory (except for position, which is saved or deleted with packet 0x8E-A6.)

These settings will control ThunderBolt E operations whenever it is cold-reset or power cycled. The following tables illustrate how the user configurable data is mapped.

Factory default settings (segment 3)

Parameter	Factory Default	Set	Request	Report
Receiver mode	4 (Full Position 3D)	0xBB	0xBB	0xBB
Dynamics code	1 (Land)	0xBB	0xBB	0xBB
Elevation mask	0.175 radians (10 deg)	0xBB	0xBB	0xBB
Signal level mask	4 (AMU)	0xBB	0xBB	0xBB
PDOP mask	12	0xBB	0xBB	0xBB
PDOP switch	6	0xBB	0xBB	0xBB
Foliage mode	1 (Sometimes)	0xBB	0xBB	0xBB

Packet I/O control (segment 4)

Parameter	Factory Default	Set	Request	Report
Packet broadcast mask				
Mask 0	0x05	0x8E-A5	0x8E-A5	0x8E-A5
Mask 1	0x00			
Packet 0x35 data				
Position (Byte 0)	0x12	0x35	0x35	0x35
Velocity (Byte 1)	0x02	0x35	0x35	0x35
Timing (Byte 2)	0x00	0x35	0x35	0x35
Auxiliary (Byte 3)	0x00	0x35	0x35	0x35
Datum	0 (WGS-84)	0x8E-15	0x8E-15	0x8E-15

Serial port configuration (segment 5)

Parameter	Factory Default	Set	Request	Report
Input baud rate	7 (9600 baud)	0xBC	0xBC	0xBC
Output baud rate	7 (9600 baud)	0xBC	0xBC	0xBC
Data bits	3 (8 bits)	0xBC	0xBC	0xBC
Parity	0 (none)	0xBC	0xBC	0xBC
Stop bits	0 (1 bit)	0xBC	0xBC	0xBC
Input protocol	2 (TSIP)	0xBC	0xBC	0xBC
Output protocol	2 (TSIP)	0xBC	0xBC	0xBC

Timing outputs (segment 6)

Parameter	Factory Default	Set	Request	Report
PPS enable	1 (enabled)	0x8E-4A	0x8E-4A	0x8E-4A
PPS sense	1 (rising edge)	0x8E-4A	0x8E-4A	0x8E-4A
PPS offset	0.0 (seconds)	0x8E-4A	0x8E-4A	0x8E-4A
Bias Uncertainty Threshold	300.0 (Meters)	0x8E-4A	0x8E-4A	0x8F-4A
PPS Output Qualifier	2 (always on)	0x8E-4E	0x8E-4E	0x8F-4E
UTC/GPS Date/Time	0 (GPS)	0x8E-A2	0x8E-A2	0x8F-A2
UTC/GPS PPS Alignment	0 (GPS)	0x8E-A2	0x8E-A2	0x8F-A2

Accurate position (segment 7)

Parameter	Factory Default	Set	Request	Report
Position	No stored position	0x31, 0x32, self-survey	0x8E-AC	0x8F-AC

Self-survey (segment 8)

Parameter	Factory Default	Set	Request	Report
Self-survey enable	1 (enabled)	0x8E-A9	0x8E-A9	0x8E-A9
Position save flag	1 (save)	0x8E-A9	0x8E-A9	0x8E-A9
Self-survey count	2000 (fixes)	0x8E-A9	0x8E-A9	0x8E-A9

Oscillator disciplining (segment 9)

Parameter	Factory Default	Set	Request	Report
Time Constant	10.0 seconds	0x8E-A8	0x8E-A8	0x8E-A8
Loop Damping	1.0	0x8E-A8	0x8E-A8	0x8E-A8
Ko	8.83 (Hz/volt)	0x8E-A8	0x8E-A8	0x8E-A8
Minimum control voltage	0.0 (volts)	0x8E-A8	0x8E-A8	0x8E-A8
Maximum control voltage	4.0 (volts)	0x8E-A8	0x8E-A8	0x8E-A8
Initial DAC voltage	2.0 (volts)	0x8E-A8	0x8E-A8	0x8E-A8
Recovery mode jam sync threshold	300.0 (ns)	0x8E-A8	0x8E-A8	0x8E-A8
Recovery mode maximum frequency offset	50.0 (ppb)	0x8E-A8	0x8E-A8	0x8E-A8

Packets output at power-up

After completing its self-diagnostics, ThunderBolt E automatically outputs packet 0x45 (Software version),

Command packets: User to ThunderBolt E

The following table summarizes the packets that can be sent to the ThunderBolt E by the user:

Input ID	Packet Description	Output ID
0x1C	Firmware/Hardware versions	0x1C
0x1E	Initiate cold, warm, or factory reset	0x45 (after reset)
0x1F	Request software version	0x45
0x24	Request GPS satellite selection	0x6D
0x25	Initiate hot reset	0x45 (after reset)
0x26	Request receiver health	0x46, 0x4B
0x27	Request signal levels	0x47
0x29	Request Almanac Health	0x49
0x31	Set accurate position (XYZ ECEF)	--
0x32	Set accurate position (Lat, Long, Alt)	--

Input ID	Packet Description	Output ID
0x34	Set satellite selection for one-satellite mode	--
0x35	Set/request I/O options	0x55
0x37	Request status and value of last position and velocity fixes	0x57 (and other enabled packets)
0x38	Load/request satellite system data	0x58
0x39	Set/request satellite disable or ignore health	0x59
0x3A	Request last raw measurement	0x5A
0x3B	Request ephemeris status	0x5B
0x3C	Request current satellite tracking status	0x5C
0x3F-11	Request EEPROM segment status	0x5F-11
0x70	Set/request filter configuration	0x70
0xBB	Set/request receiver configuration	0xBB
0xBC	Set/request serial port configuration	0xBC
0x8E-15	Set/request current datum	0x8F-15
0x8E-26	Save configuration	0x45 (after reset)
0x8E-41	Request manufacturing parameters	0x8F-41
0x8E-42	Request production parameters	0x8F-42
0x8E-45	Set configuration segment parameters to factory defaults	0x8F-45
0x8E-4A	Set/request PPS characteristics	0x8F-4A
0x8E-4C	Save configuration segment to NVS	0x8F-4C
0x8E-4E	Set/request PPS output option	0x8F-4E
0x8E-A0	Set/request DAC value	0x8F-A0
0x8E-A2	Set/request UTC/GPS timing	0x8F-A2
0x8E-A3	Issue oscillator disciplining command	0x8F-A3
0x8E-A4	Set test modes	0x8F-A4
0x8E-A5	Set/request packet broadcast mask	0x8F-A5
0x8E-A6	Issue self-survey command	0x8F-A6
0x8E-A8	Set/request oscillator disciplining parameters	0x8F-A8
0x8E-A9	Set/request self-survey parameters	0x8F-A9
0x8E-AB	Request primary timing packet	0x8F-AB
0x8E-AC	Request supplemental timing packet	0x8F-AC

Report packets: ThunderBolt E to User

The following table summarizes the packets output by ThunderBolt E:

Output ID	Packet Description	Input ID
0x1C	Firmware/Hardware Versions	0x1C
0x42	Single-precision XYZ position	0x37, auto
0x43	Velocity fix (XYZ ECEF)	0x37, auto
0x45	Software version information	0x1E, 0x1F, power-up
0x46	Receiver health	0x26, auto

Output ID	Packet Description	Input ID
0x47	Signal level for all satellites	0x27, auto
0x49	Almanac health	0x29
0x4A	Single-precision LLA position	0x37, auto
0x4B	Receiver health	0x26, auto
0x55	I/O options	0x35
0x56	Velocity fix (ENU)	0x37, auto
0x57	Information about last computed fix	0x37
0x58	GPS system data/acknowledge	0x38
0x59	Sat enable/disable & health flag	0x39
0x5A	Raw measurement data	0x3A
0x5B	Ephemeris status	0x3B
0x5C	Satellite tracking status	0x3C
0x5F-11	EEPROM segment status	0x3F-11
0x6D	Satellite selection list	0x24, auto
0x83	Double-precision XYZ	0x37, auto
0x84	Double-precision LLA	0x37, auto
0x70	Filter configuration	0x70
0xBB	Receiver configuration	0xBB
0xBC	Serial port configuration	0xBC
0x8F-15	Current datum values	0x8E-15
0x8F-41	Stored manufacturing operating parameters	0x8E-41
0x8F-42	Stored production parameters	0x8E-42
0x8F-45	Configuration parameters set to factory defaults	0x8F-45
0x8F-4A	PPS characteristics	0x8E-4A
0x8F-4C	Configuration segment saved to NVS	0x8F-4C
0x8F-4E	PPS output option	0x8E-4E
0x8F-A0	DAC setting	0x8E-A0
0x8F-A2	UTC/GPS timing	0x8E-A2
0x8F-A3	Oscillator disciplining command	0x8E-A3
0x8F-A4	Test modes	0x8E-A4
0x8F-A5	Packet broadcast mask	0x8E-A5
0x8F-A6	Self-survey command	0x8E-A6
0x8F-A8	Oscillator disciplining parameters	0x8E-A8
0x8F-A9	Self-survey parameters	0x8E-A9
0x8F-AB	Primary timing packet	0x8E-AB, auto
0x8F-AC	Supplemental timing packet	0x8E-AC, auto

Packet structure

TSIP packet structure is the same for both commands and reports. The packet format is **<DLE> <id> <data string bytes> <DLE> <ETX>**

Where:

- **<DLE>** is the byte 0x10
- **<ETX>** is the byte 0x03
- **<id>** is a packet identifier byte, which can have any value except **<ETX>** and **<DLE>**.

The bytes in the data string can have any value. To prevent confusion with the frame sequences **<DLE> <id>** and **<DLE> <ETX>**, every **<DLE>** byte in the data string is preceded by an extra **<DLE>** byte ('stuffing'). These extra **<DLE>** bytes must be added before sending a packet and removed after receiving the packet. A simple **<DLE> <ETX>** sequence does not necessarily signify the end of the packet, as these can be bytes in the middle of a data string. The end of a packet is **<ETX>**, preceded by an odd number of **<DLE>** bytes.

Floating point numbers (single, double) follow the IEEE Standard for Binary Floating-Point Arithmetic (IEEE 754.) Multiple-byte numbers (integer, single and double) are sent most-significant byte first.

Note – On Intel-based (little-endian) machines you must switch the byte order.

The data types used in TSIP are as follows:

Data type	Description
UINT8	An 8-bit unsigned integer (0 to 255)
SINT8	An 8-bit signed integer (-128 to 127)
INT16	A 16-bit unsigned integer (0 to 65,535)
SINT16	A 16-bit signed integer (-32,768 to 32,767)
UINT32	A 32-bit unsigned integer (0 to 4,294,967,295)
SINT32	A 32-bit signed integer (-2,147,483,648 to 2,147,483,647)
Single	Single-precision float (4 bytes) (1.2x10 ⁻³⁸ to 3.4x10 ³⁸)
Double	Double-precision float (8 bytes) (2.2x10 ⁻³⁰⁸ to 1.8x10 ³⁰⁸)

Note – Default serial port settings are 9600, 8-None-1.

Packet descriptions

Packet descriptions used in run mode

Report packet 0X13 unparseable packet

This packet is sent in response to a received packet that was unparseable. A packet is unparseable if the packet ID is not recognized or if the length or content of the packet is not correct for the packet ID.

Byte	Type	Item
0	UINT8	Packet ID of unparseable packet
1-N	UINT8	Packet data bytes of unparseable packet

Command packet 0x1C:01 - Firmware version

The command packet 0x1C: 01 may be issued to obtain the firmware version. The packet format is defined in the following table:

Byte	Item	Type	Value	Definition
0	Packet ID	U8	0x1C	Packet ID 0x1C
1	Sub-code	U8	0x01	Sub-code 0x01 for software component version information request.

Report packet 0x1C:81 - Report firmware version

Byte	Item	Type	Value	Definition
0	Packet ID	U8	0x1C	Packet ID 0x1C
1	Sub-code	U8	0x81	Sub-code 0x81 for software component version information report.
2	Reserved	U8	Any	Reserved
3	Major version	U8	Any	Firmware major version
4	Minor version	U8	Any	Firmware minor version
5	Build number	U8	Any	Firmware build number
6	Month	U8	1-12	Firmware build month
7	Day	U8	1-31	Firmware build day
8...9	Year	U16	Any	Firmware build year
10	Length of first module name	U8	Any	The length of the product name (L1)
11 ... (10+L1)	Product name	U8	String	Product name string in ASCII

Command packet 0x1C: 03 - Hardware component version information

- The command packet 0x1C: 03 may be issued to obtain the hardware component version information.
- The report packet is of variable length, depending on the length of the hardware ID.
- The serial number, build date fields, and the hardware ID are programmed into the ThunderBolt E at production.
- The hardware code is 3007.

Byte	Item	Type	Value	Definition
0	Packet ID	U8	0x1C	Packet ID 0x1C
1	Sub-code	U8	0x03	Sub-code 0x03 for hardware component version information request.

Report packet 0x1C: 83 - Hardware component version information

Byte	Item	Type	Value	Definition
0	Packet ID	U8	0x1C	Packet ID 0x1C
1	Sub-code	U8	0x83	Sub-code 0x83 for hardware component version information report.
2 ... 5	Serial number	U32	Any	Board serial number
6	Build day	U8	1-31	Day of the board's build date
7	Build month	U8	1-12	Month of the board's build date
8...9	Build year	U16	Any	Year of the board's build date
10	Build hour	U8	0-23	Hour of the board's build date
11 ... 12	Hardware code	U16	Any	Hardware code associated with the hardware ID
13	Length of hardware ID	U8	Any	The length of the hardware ID (L)
14 (13 + L)	Hardware ID	U8	String	Hardware ID string in ASCII

Command Packet 0x1E: Initiate Cold, Warm, or Factory Reset

This packet commands receiver to perform either a cold reset, warm reset or a factory reset. A cold reset will clear the GPS data (almanac, ephemeris, etc.) stored in RAM and is equivalent to a power cycle. A factory reset will additionally restore the factory defaults of all configuration parameters stored in flash memory. A warm reset clears ephemeris and oscillator uncertainty but retains the last position, time and almanac. This packet contains one data byte. The data format is shown below.

Byte	Item	Type	Value	Meaning
0	Reset	UINT8	0x4B	Cold reset
			0x0E	Warm reset
			0x46	Factory reset

Note – The factory reset command will delete the stored position and cause a self-survey to restart.

Command Packet 0x1F: Request Software Version

This packet requests information about the version of software in ThunderBolt E. This packet contains no data. The requested data is returned in packet 0x45.

Command Packet 0x24: Request GPS Satellite Selection

This packet requests a list of satellites used for the current position/time fix. This packet contains no data. The requested data is returned in packet 0x6D.

Command Packet 0x25: Initiate Hot Reset

This packet commands the GPS receiver to perform a hot reset. This is not equivalent to cycling the power; RAM is not cleared. This packet contains no data.

Command Packet 0x26: Request Receiver Health

This packet requests receiver health status. This packet contain no data. The requested data is returned in packet 0x46 and packet 0x4B.

Command Packet 0x27: Request Signal Levels

This packet requests signal levels for all satellites currently being tracked. This packet contain no data. The requested data is returned in packet 0x47.

Command Packet 0x29: Request Almanac Health

This packet requests Almanac health data. This packet contain no data. The requested data is returned in packet 0x49.

Command Packet 0x31: Accurate Initial Position (XYZ Cartesian ECEF)

This packet provides an accurate initial position to the GPS receiver in XYZ coordinates. Either the single precision or the double precision version of this packet may be used, however, we recommend using the double precision version for greatest accuracy. ThunderBolt E uses this position for performing time-only fixes. If a survey is in progress when this command is sent, the survey is aborted and this position data is used immediately. ThunderBolt E will automatically switch to the Over-Determined Timing mode when this command is issued. Note that this position is not automatically saved to flash memory. If you want to save this position, first set the position, wait at least 2 seconds and then use packet 0x8E-A6 to save the position.

Command Packet 0x31 Data Format (single precision)

Byte	Item	Type	Units
0-3	X-axis	Single	Meters
4-7	Y-axis	Single	Meters
8-11	Z-axis	Single	Meters

Command Packet 0x31 Data Format (double precision)

Byte	Item	Type	Units
0-7	X-axis	Double	Meters
8-15	Y-axis	Double	Meters
16-23	Z-axis	Double	Meters

Command Packet 0x32: Accurate Initial Position (Latitude, Longitude, Altitude)

This packet provides an accurate initial position to the GPS receiver in latitude, longitude, and altitude coordinates. Either the single precision or the double precision version of this packet may be used, however, we recommend using the double precision version for greatest accuracy. The GPS receiver uses this position for performing time-only fixes. If a survey is in progress when this command is issued, the survey is aborted, and this position data is used immediately. The coordinates entered must be in the WGS-84 datum. ThunderBolt E will automatically switch to the Over-Determined Timing mode when this command is issued. Note that this position is not automatically saved to flash memory. If you want to save this position, first set the position, wait at least 2 seconds and then use packet 0x8E-A6 to save the position.

Note – When converting from degrees to radians use the following value for $p = 3.1415926535898$

Command Packet 0x32 Data Format (single precision)

Byte	Item	Type	Units
0-3	Latitude	Single	Radians, (+ for north, - for south)
4-7	Longitude	Single	Radians, (+ for east, - for west)
8-11	Altitude	Single	Meters

Command Packet 0x32 Data Format (double precision)

Byte	Item	Type	Units
0-7	Latitude	Double	Radians, (+ for north, - for south)
8-15	Longitude	Double	Radians, (+ for east, - for west)
16-23	Altitude	Double	Meters

Command Packet 0x34: Satellite Selection For One-Satellite Mode

This packet allows the user to control the choice of the satellite to be used for the one-satellite time-only fix mode. This packet contains one byte. If the byte value is 0, the GPS receiver automatically chooses the best satellite. This automatic selection of the best satellite is the default action, and the GPS receiver does this unless it receives this packet. If the byte value is from 1 to 32, the packet specifies the PRN number of the satellite to be used.

Command Packet 0x35: Set or Request I/O Options

This packet requests the current I/O option states and allows the I/O option states to be set as desired.

To request the option states without changing them, the user sends this packet with no data bytes. To change any option states, the user includes 4 data bytes with the values. The I/O options, their default states, and the byte values for all possible states are shown below. These options can be set into non-volatile memory with the 0x8E-4C-04 command. The GPS receiver returns packet 0x55.

The following abbreviations apply:

- ALT (Altitude)
- ECEF (Earth centered, Earth-fixed)
- XYZ (Cartesian coordinates)
- LLA (latitude, longitude, altitude)
- HAE (height above ellipsoid)
- WGS-84 (Earth model (ellipsoid))
- MSL geoid (mean sea level)

- UTC (universal coordinated time)

Byte	Data Type	Bit	Value	Meaning	Associated Packet		
0	Position	0	0	ECEF off	0x42 or 0x83		
			1	ECEF on			
		1	0	LLA off	0x4A or 0x84		
			1	LLA on			
		2	0	HAE (datum)	0x4A or 0x84		
			1	MSL geoid ¹			
		3	0	reserved			
			4	0		single-precision position	0x42/4A
					1	double-precision position	0x83/84
					5	0	Superpacket 0x8F-20 off
			1	Superpacket 0x8F-20 on		0x8F-20	
1	Velocity	0	0	ECEF off	0x43		
			1	ECEF on			
		1	0	ENU off	0x56		
			1	ENU on			
		2:7	0	reserved			
2	Timing	0	0	GPS time reference	0x42, 0x43, 0x4A, 0x83, 0x84, 0x56		
			1	UTC time reference			
		1	0	Compute fix ASAP	0x42, 0x43, 0x4A, 0x83, 0x84, 0x56		
			1	Compute fix on integer second			
		2	0	0x37Time of fix: when computed	0x37		
			1	0x37Time of fix: on request			
		3	0	Simultaneous meas. Status off			
			1	Simultaneous meas. Status on			
		4	0	Minimum projection off			
			1	Minimum projection on			
5:7	0	reserved					
3	Auxiliary	0	0	Raw measurement packet 5A off	0x5A		
			1	Raw measurement packet 5A on			
		1	0	Raw codephase measurements			
			1	Filtered codephase measurements			
		2:7	0	reserved			

¹When using the MSL altitude output, the current datum must be set to WGS-84.

Command Packet 0x37: Request Status and Values of Last Position

This packet requests information regarding the last position fix (normally used when the GPS receiver is not automatically outputting fixes). The GPS receiver returns the position/ velocity auto packets specified in the 0x35 message as well as message 0x57. This packet contains no data.

Command Packet 0x38: Request Satellite System Data

This packet requests current satellite data. The GPS receiver returns packet 0x58.

Byte	Item	Type	Value	Meaning
0	Operation	UINT8	1	Must always be '1'
1	Type of data	UINT8	2	Almanac
			3	Health page, toa, WNa
			4	Ionosphere
			5	UTC
			6	Ephemeris
			2	Sat PRN
			1 - 32	Satellite PRN number

Command Packet 0x39: Set or Request SV Disable and Health Use

Normally the GPS receiver selects only healthy satellites (based on transmitted values in the ephemeris and almanac) which satisfy all mask values. This packet allows overriding the internal logic and forces the receiver to either unconditionally disable a particular satellite or to ignore a bad health flag. The GPS receiver returns packet 0x59 if operation 3 or 6 is requested; otherwise there is no reply.

It should be noted that when viewing the satellite disables list, the satellites are not numbered but are in numerical order. The disabled satellites are signified by a "1" and enabled satellites are signified by a "0".

Byte	Item	Type	Value	Meaning
0	Operation	UINT8	1	Enable satellite (default)
			2	Disable satellite
			3	Request enable/disable status of all 32 satellites
			4	Heed health (default)
			5	Ignore health
			6	Request heed or ignore health on all 32 satellites
1	Sat PRN	UINT8	0	All 32 satellites
			1-32	Any one satellite PRN number

Note – At power-on and after a reset the default values are set for all satellites.

C

CAUTION – Improperly ignoring health can cause the GPS receiver software to lock up, as an unhealthy satellite may contain defective data. Use extreme caution in ignoring satellite health.

Command Packet 0x3A: Request Last Raw Measurement

This packet requests the most recent raw measurement data for one specified satellite. The GPS receiver returns packet 0x5A if data is available.

Byte	Item	Type	Value	Meaning
0	Satellite PRN	UINT8	0	All satellites in current tracking set
			1-32	Specific desired satellite

Command Packet 0x3B: Request Ephemeris Status

This packet requests the current status of satellite ephemeris data. The GPS receiver returns packet 0x5B if data is available.

Byte	Item	Type	Value	Meaning
0	Satellite PRN	UINT8	0	All satellites in current tracking set
			1-32	Specific desired satellite

Command Packet 0x3C: Request Satellite Tracking Status

This packet requests the current satellite tracking status. The GPS receiver returns packet 0x5C if data is available.

Byte	Item	Type	Value	Meaning
0	Satellite PRN	UINT8	0	All satellites in current tracking set
			1-32	Specific desired satellite

Command Packet 0x3F-11: Request EEPROM Segment Status

This packet requests the current satellite tracking status. The GPS receiver returns packet 0x5C if data is available.

Byte	Item	Type	Value	Meaning
0	Satellite PRN	UINT8	0	All satellites in current tracking set
			1-32	Specific desired satellite

Report Packet 0x42: Single-precision Position Fix

This packet provides current GPS position fix in XYZ ECEF coordinates. If the I/O "position" option is set to "XYZ ECEF" and the I/O "Precision-of-Position output" is set to single-precision, then the GPS receiver sends this packet each time a fix is computed or in response to packet 0x37. The data format is shown below. The time-of-fix is in GPS or UTC as selected by the I/O "timing" option in packet 0x35. Packet 0x83 provides a double-precision version of this information.

Byte	Item	Type	Units
0-3	X	Single	meters
4-7	Y	Single	meters
8-11	Z	Single	meters
12-15	time-of-fix	Single	seconds

Report Packet 0x43: Velocity Fix, XYZ ECEF

This packet provides current GPS velocity fix in XYZ ECEF coordinates. If the I/O "velocity" option (packet 0x35) is set to "XYZ ECEF," then the GPS receiver sends this packet each time a fix is computed or in response to packet 0x37. The data format is shown below. The time-of-fix is in GPS or UTC as selected by the I/O "timing" option.

Byte	Item	Type	Units
0-3	X velocity	Single	meters/second
4-7	Y velocity	Single	meters/second
8-11	Z velocity	Single	meters/second
12-15	bias rate	Single	meters/second
16-19	time-of-fix	Single	seconds

Report Packet 0x45: Software Version Information

This packet provides information about the version of firmware running on the GPS receiver. The receiver sends this packet after power-on, reset, and in response to packet 0x1F.

Byte	Item	Type
0	Major version number of application	UINT8
1	Minor version number of application	UINT8
2	Month	UINT8
3	Day	UINT8
4	Year number minus 1900	UINT8
5	Major revision number of GPS core	UINT8
6	Minor revision number of GPS core	UINT8
7	Month	UINT8

Byte	Item	Type
8	Day	UINT8
9	Year number minus 1900	UINT8

Note – Bytes 0 through 4 are part of the application layer of the firmware, while bytes 5 through 9 are part of the GPS core layer of the firmware.

Report Packet 0x46: Receiver Health

This packet provides receiver health status. The receiver sends this packet in response to packet 0x26.

Byte	Item	Type	Value	Meaning
0	SV Fix Status	bit field	0x00	Doing fixes
			0x01	Do not have GPS time yet
			0x03	PDOP too high
			0x0C	Bad 1 SV
			0x08	No usable SVs
			0x09	Only 1 usable SV
			0x0A	Only 2 usable SVs
			0x0B	Only 3 usable SVs
			0xBB	Over-Determined Clock mode
1	Antenna Fault status	bit field	Bit 0	0 if Warm start, 1 otherwise unused
			Bits 1-3	0000 = no fault
			Bits 4-7	0001 = antenna circuit open
				0011 = antenna circuit short

Report Packet 0x47: Signals Levels for Tracked Satellites

This packet provides received signal levels for all satellites currently being tracked or on which tracking is being attempted (i.e., above the elevation mask and healthy according to the almanac). The receiver sends this packet in response to packet 0x27 or automatically as listed in the Automatic Output Packets section. The data format is shown below. Up to 12 satellite number/signal level pairs may be sent as indicated by the count field. Signal level is normally positive. If it is zero then that satellite has not yet been acquired. If it is negative then that satellite is not currently in lock. The absolute value of signal level field is the last known signal level of that satellite.

Byte	Item	Type
0	Count	UINT8
1	Satellite number 1	UINT8
2-5	Signal level 1	Single
6	Satellite number 2	UINT8
7-10	Signal level 2	Single
(etc.)	(etc.)	(etc.)

Note – *The signal level provided in this packet is a linear measure of the signal strength after correlation or de-spreading. Units are either AMU or dB-Hz as controlled by packet 0x35.*

Report Packet 0x49: Almanac Health

This packet provides health data on 32 satellites. Packet data consists of a data byte for each of 32 satellites, each data byte containing the 6-bit health from almanac page 25.

Byte	Item	Type
0	Health of satellite #1	bit field
1	Health of satellite #1	bit field
2	Health of satellite #1	bit field
-	-	-
31	Health of satellite #31	bit field

Report Packet 0x4A: Single Precision LLA Position Fix

The packet provides current GPS position fix in LLA (latitude, longitude, and altitude) coordinates. If the I/O position option is set to "LLA" and the I/O precision of position output is set to single precision, then the receiver sends this packet each time a fix is computed. The data format is shown below:

Byte	Item	Type	Units
0-3	Latitude	Single	radians: + for north, - for south
4-7	Longitude	Single	radians: + for east, - for west
8-11	Altitude	Single	meters
12-15	Clock Bias	Single	meters
16-19	Time-of-fix	Single	seconds

The LLA conversion is done according to the datum selected using packet 0x8E-15. The default is WGS-84. Altitude is referred to the datum or the MSL Geoid, depending on which I/O LLA altitude option is selected with packet 0x35. The time of fix is in GPS time or UTC, depending on which I/O timing option is selected.

C CAUTION – When converting from radians to degrees, significant and readily visible errors will be introduced by use of an insufficiently precise approximation for the constant π (pi). The value of a constant π as specified in ICD-GPS-200 is 3.1415926535898.

C CAUTION – The MSL option is only valid with the WGS-84 datum. When using other datums, only the HAE option is valid.

Report Packet 0x4B: Receiver Health

This packet provides receiver health status.

Byte	Item	Type	Value	Meaning
0	Machine ID	UINT8	96	Receiver Machine ID
1	RTC Time validity	Bit pattern	Bit 1	0 = RTC time valid 1 = RTC time not valid
			Bit 3	0 = Almanac not complete 1 = Almanac collection complete
2	TSIP Superpacket support	UNIT8	1	Superpackets supported
			0	Superpackets not supported

Report Packet 0x55: I/O Options

This packet provides the current I/O option states in response to packet 0x35 request. The data format is the same as for packet 0x35, see [Command Packet 0x35: Set or Request I/O Options](#), page 47.

Report Packet 0x56: Velocity Fix, East-North-Up (ENU)

If East-North-Up (ENU) coordinates have been selected for the I/O "velocity" option, the receiver sends this packet each time that a fix is computed or in response to packet 0x37. The data format for this packet is shown below.

Byte	Item	Type	Units
0-3	East Velocity	Single	m/s; + for east, - for west
4-7	North Velocity	Single	m/s; + for north, - for south
8-11	Up velocity	Single	m/s; + for up, - for down
12-15	Clock bias rate	Single	m/s
16-19	Time-of-fix	Single	seconds

Note – The time-of-fix is in GPS or UTC time as selected by the I/O "timing" option.

Report Packet 0x57: Information about Last Computed Fix

This packet provides information concerning the time and origin of the previous position fix. The receiver sends this packet, among others, in response to packet 0x37. The data format for this packet is shown below.

Byte	Item	Type	Value	Meaning
0	Source of info	UINT8	0	Old fix
			1	New fix
1	Fix mode	UINT8	0	No previous fix
			1	Time only 1-SV
			2	2D clock hold (not used)
			3	2D
			4	3D
			5	Over-Determined Clock
			6	DGPS reference (not used)
2-5	Time of last fix	Single		Seconds GPS time
6-7	Week of last fix	UINT16		Weeks

Report Packet 0x58: GPS System Data from the Receiver

This packet provides GPS data (almanac, ephemeris, etc.). The GPS receiver sends this packet in response to packet 0x38. The data format is shown below. The table and section numbers referred to in the "Meaning" column reference the *Global Positioning System Standard Positioning Service Signal Specification* document.

Report Packet 0x58 Data Format

Byte	Item	Type	Value	Meaning
0	operation	UINT8	2	Data out
			3	no data on SV
1	Type of data	UINT8	2	Almanac
			3	Health page, T_oa, WN_oa
			4	Ionosphere
			5	UTC
			6	Ephemeris
2	Sat PRN #	UINT8	0	Data that is not satellite ID-specific
			1 to 32	Satellite PRN number
3	Length (n)	UINT8		Byte count
4 to n+3	Data			

Note – If data is not available, byte 3 is set to 0 and no data is sent

Report Packet 0x58 Almanac Data Type 2

Byte	Item	Type	Value	Meaning
4	Toa (raw)	UINT8		Table 2.8
5	SV_HEALTH	UINT8		Table 2.8
6-9	e	Single		Table 2.8
10-13	toa	Single		Table 2.8
14-17	io	Single		Table 2.8
18-21	OMEGADOT	Single		Table 2.8
22-25	sqrt(A)	Single		Table 2.8
26-29	(OMEGA)0	Single		Table 2.8
30-33	(OMEGA)	Single		Table 2.8
34-37	MO	Single		Table 2.8
38-41	af0	Single		Table 2.8
42-45	af1	Single		Table 2.8
46-49	Axis	Single		Table 2.8
50-53	n	Single		Table 2.8
54-57	OMEGA_n	Single		Derived
58-61	ODOT_n	Single		Derived
62-65	tzc	Single		Time of collection (set to -1.0 if there is no data available)
66-67	week number	UINT16		GPS week number
68-69	WNa	UINT16		Sec 2.4.5.2.3

Note – All angles are in radians.

Report Packet 0x58 Almanac Health Data Type 3

Byte	Item	Type	Meaning
4	Week number for health	UINT8	Sec 2.4.5.3
5-36	SV health	UINT8	Sec 2.4.5.3
37	toa for health	UINT8	Sec 2.4.5.2.3
38	current toa	UINT8	Time of collection
39-40	current week number	UINT16	Time of collection

Report Packet 0x58 Ionosphere Data Type 4

Byte	Item	Type	Meaning
4-11	not used		
12-15	a0	Single	Sec 2.4.5.6
16-19	a1	Single	Sec 2.4.5.6
20-23	a2	Single	Sec 2.4.5.6
24-27	a3	Single	Sec 2.4.5.6
28-31	b0	Single	Sec 2.4.5.6

Byte	Item	Type	Meaning
32-35	b1	Single	Sec 2.4.5.6
36-39	b2	Single	Sec 2.4.5.6
40-43	b3	Single	Sec 2.4.5.6

Report Packet 0 x 58 UTC Data Type 5 (continued)

Byte	Item	Type	Meaning
4-16	not used		
17-24	A0	Double	Sec 2.4.5.5
25-28	A1	Single	Sec 2.4.5.5
29-30	DtLS	SINT16	Sec 2.4.5.5
31-34	tot	Single	Sec 2.4.5.5
35-36	Wnt	UINT16	Sec 2.4.5.5
37-38	WNLSF	UINT16	Sec 2.4.5.5
39-40	DN	UINT16	Sec 2.4.5.5
41-42	DtLSf	SINT16	Sec 2.4.5.5

Report Packet 0 x 58 Ephemeris Data Type 5

Byte	Item	Type	Meaning
4	SV number	UINT8	SV PRN number
5-8	t_ephem	Single	Time of collection (seconds)
9-10	week number	UINT16	GPS week number 0 through 1023
11	retired		
12	retired		
13	SV accuracy raw	UINT8	URA index of SV (0 through 15)
14	SV health	UINT8	6 bit health code
15-16	IODC	UINT16	Issue of data clock
17-20	tGD	Single	L1-L2 correction term
21-24	toc	Single	Sec 20.4.3.5
25-28	af2	Single	Sec 2.4.3.6
29-32	af1	Single	Sec 2.4.3.6
33-36	afo	Single	Sec 2.4.3.6
37-40	SV accuracy	Single	URA of SV
41	IODE	UINT8	Issue of data ephemeris
42	retired		
43-46	Crs	Single	Table 2.5
47-50	Dn	Single	Table 2.5
51-58	MO	Double	Table 2.5
59-62	Cuc	Single	Table 2.5
63-70	e	Double	Table 2.5
71-74	CUS	Single	Table 2.5

Byte	Item	Type	Meaning
75-82	sqrt(A)	Double	Table 2.5
83-86	toe	Single	Table 2.5
87-90	Cic	Single	Table 2.5
91-98	(OMEGA)0	Double	Table 2.5
99-102	Cis	Single	Table 2.5
103-110	io	Double	Table 2.5
111-114	Crc	Single	Table 2.5
115-122	(OMEGA)	Double	Table 2.5
123-126	OMEGADOT	Single	Table 2.5
127-130	IDOT	Single	Table 2.5
131-138	Axis	Double	
139-146	n	Double	
147-154	r1me2	Double	= sqrt(1.0-e2)
155-162	OMEGA_n	Double	Derived from OMEGA_0, OMEGADOT
163-170	ODOT_n	Double	Derived from OMEGADOT

Note – All angles are in radians. Reference numbers refer to Global Positioning System Standard Positioning Service Signal Specification. This specification is currently available in Adobe Acrobat format at www.navcen.uscg.gov/pubs/gps/sigspec/.

Report Packet 0x59: Status of Satellite Disable or Ignore Health

This packet is sent in response to command packet 0x39.

Byte	Item	Type	Value	Meaning
0	Operation	UINT8	3	The remaining bytes tell whether the receiver has enabled each satellite for selection.
			6	The remaining bytes tell whether the receiver heeds or ignores each satellite's health as a criterion for selection.
1 to 32	Sat PRN	UINT8 (1 per SV)	0	Enable satellite selection or heed satellite's health.
			1	Disable satellite selection or ignore satellite's health.

Report Packet 0x5A: Raw Data Measurement Data

Packet 0x5A provides raw GPS measurement data. This packet is sent in response to packet 0x3A or automatically if enabled with packet 0x35.

Byte	Item	Type	Units
0	SV PRN number	UINT8	
1-4	Sample length	Single	milliseconds

Byte	Item	Type	Units
5-8	Signal level	Single	AMU or dB-Hz
9-12	Code phase	Single	1/16th chip
13-16	Doppler	Single	Hertz @ L1
17-24	Time of measurement	Double	seconds

Note – The sample length is the number of milliseconds over which the sample was averaged.

Note – The code phase value is the average delay over the sample interval of the received C/A code, and is measured with respect to the receiver's millisecond timing reference.

Report Packet 0x5B: Satellite Ephemeris Status

Packet 0x5B provides satellite ephemeris status. This packet is sent in response to packet 0x3B.

Byte	Item	Type	Units
0	SV PRN number	UINT8	
1-4	Time of collection	Single	seconds
5	Health	UINT8	
6	IODE	UINT8	
7-10	toe	Single	seconds
11	Fit interval flag	UINT8	
12-15	SV accuracy (URA)	Single	meters

Report Packet 0x5C: Satellite Tracking Status

The receiver sends this packet in response to command packet 0x3C.

Byte	Bit	Item	Type	Value	Meaning
0		SV PRN number	UINT8	1-32	PRN
1	0:2	slot number	bit field	0 0 0	Not used
1	3:7	channel number	bit field	0 0 0 0	Channel 1
				0 0 0 1	Channel 2
				0 0 1 0	Channel 3
				0 0 1 1	Channel 4
				0 1 0 0	Channel 5
				0 1 0 1	Channel 6
				0 1 1 0	Channel 7
				0 1 1 1	Channel 8
				1 0 0 0	Channel 9
				1 0 0 1	Channel 10
				1 0 1 0	Channel 11

Byte	Bit	Item	Type	Value	Meaning
				1 0 1 1	Channel 12

Byte	Bit	Item	Type	Value	Meaning
2		acquisition flag	UINT8	0	Never acquired
				1	Acquired
				2	Re-opened search
3		ephemeris flag	UINT8	0	Flag not set
				>0	Good ephemeris
4-7		signal level	Single		AMU or dBHz
8-11		time of last measurement	Single	secs	GPS time of week
12-15		elevation angle	Single		Radians
16-19		azimuth angle	Single		Radians
20		old measurement flag	UINT8	0	Flag not set
				>0	Measurement old
21		integer msec flag	UINT8	0	Don't know msec
				1	Known from subframe
				2	Verified by bit crossing
				3	Verified by good fix
				4	Suspect msec error
22		bad data flag	UINT8	0	Flag not set
				1	Bad parity
				2	Bad ephemeris health
23		data collection flag	UINT8	0	Flag not set
				>0	Collection in progress

Report Packet 0x5F-11: EEPROM Segment Status

The receiver sends this packet in response to command packet 0x3F-11. This packet contains the status of all EEPROM segments:

- A zero in the status bit indicates that the segment contents are valid.
- A one in the status bit indicates that the segment contents were found to be corrupt and had to be reverted to their factory default values.
- Bits 3-9 are used to generate the minor alarm (bit 10) in packet 0x8F-AC.

Byte	Bit	Item	Type	Value	Meaning
0		Subcode	UINT8	0x11	
1-2	0	Segment status	bit field		Manufacturing data
	1				Unused
	2				Unused
	3				Receiver configuration
	4				Packet I/O control
	5				Serial port configuration
	6				Timing outputs
	7				Accurate position
	8				Self-survey configuration
	9				Oscillator Disciplining parameters
	10-15				Unused

Report Packet 0x6D: Satellite Selection List

This packet provides a list of satellites used for position or time-only fixes by the GPS receiver. The packet also provides the PDOP, HDOP, VDOP and TDOP of that set and provides the current mode (automatic or manual, 3-D or 2-D, Over-Determined Clock mode, etc.). This packet has variable length equal to 17+nsvs where "nsvs" is the number of satellites used in the solution. If an SV is rejected for use by the T-RAIM algorithm then the SV PRN value will be negative.

The GPS receiver sends this packet in response to packet 0x24 or automatically. The data format is shown below.

Byte	Bit	Item	Type	Value	Meaning
0	0:2	fix dimension	bit field	1	1D clock fix
				3	2D fix
				4	3D fix
				5	OD clock fix
	3	fix mode	bit field	0	Auto
				1	Manual
	4:7	Number of SVs in fix	bit field	0-12	Count
1-4		PDOP	Single		PDOP
5-8		HDOP	Single		HDOP

Byte	Bit	Item	Type	Value	Meaning
9-12		VDOP	Single		VDOP
13-16		TDOP	Single		TDOP
17 - n		SV PRN	SINT8	± (1-32)	PRN

Command Packet 0x70: Filter Configuration

This packet provides control for the available filters. The PV filter smoothes position data when the antenna is moving and attempts to reduce the effects of position disturbances, which include reflected signals and small outages of DGPS corrections. Command Packet 0x70 enables or disables the P/V Filter, Static Filter, Altitude Filter, Kalman filter. Filter selection is restricted by the following:

- The PV filter must be turned on before the Static Filter can operate.
- The Kalman filter takes precedence, i.e., enabling the Kalman filter will disable the PV, Static, and Altitude filters

To request the filter operation state, send Command Packet 0x70 with no data bytes.

Byte	Item	Type	Value	Meaning
0	PV filter	UINT8	0	Off
			1	On
1	Static filter	UINT8	0	Off
			1	On
2	Altitude filter	UINT8	0	Off
			1	On
3	Kalman filter	UINT8	0	Off
			1	On

Report Packet 0x70: Filter Configuration

This packet reports the current configuration for the available filters.

Byte	Item	Type	Value	Meaning
0	PV filter	UINT8	0	Off
			1	On
1	Static filter	UINT8	0	Off
			1	On
2	Altitude filter	UINT8	0	Off
			1	On
3	Kalman filter	UINT8	0	Off
			1	On

Report Packet 0x83: Double Precision XYZ

This packet provides current GPS position fix in XYZ ECEF coordinates. If the I/O "position" option is set to "XYZ ECEF" and the I/O double position option is selected, the receiver sends this packet each time a fix is computed. The data format is shown below.

Byte	Item	Type	Units
0-7	X	Double	meters
8-15	Y	Double	meters
16-23	Z	Double	meters
24-31	clock bias	Double	meters
32-35	time-of-fix	Single	seconds

Note – The time-of-fix is in GPS time or UTC, as selected by the I/O "timing" option. Packet 0x42 provides a single-precision version of this information.

Report Packet 0x84: Double Precision LLA Position (Fix and Bias Information)

This packet provides current GPS position fix in LLA coordinates. If the I/O "position" option is set to "LLA" and the double position option is selected (see packet 0x35), the receiver sends this packet each time a fix is computed.

Byte	Item	Type	Units
0-7	latitude	Double	radians: + for north, - for south
8-15	longitude	Double	radians: + for east, - for west
16-23	altitude	Double	meters
24-31	clock bias	Double	meters
32-35	time-of-fix	Single	seconds

Note – The time-of-fix is in GPS time or UTC time as selected by the I/O "timing" option.

C

CAUTION – When converting from radians to degrees, significant and readily visible errors will be introduced by use of an insufficiently precise approximation for the constant π . The value of the constant π as specified in ICD-GPS-200 is 3.1415926535898.

Command Packet 0xBB: Set Receiver Configuration

In query mode, packet 0xBB is sent with a single data byte and returns report packet 0xBB in the format shown below.

Command Packet 0xBB Data Format (query only)

Byte	Item	Type	Value	Meaning
0	Subcode	UINT8	0	Query mode

TSIP packet 0xBB is used to set the GPS Receiver options. The table below lists the individual fields within the 0xBB packet.

Report Packet 0xBB Data Format

Byte	Item	Type	Value	Meaning
0	Subcode	UINT8	0	Primary receiver configuration block
1	receiver mode	UINT8	0	Automatic (2D/3D)
			1	Single satellite (1 SV time)
			3	Horizontal (2D)
			4	Full position (3D)
			7	Over-Determined Clock
2	reserved	UINT8	0xFF	do not alter
3	Dynamics Code	UINT8	1	Land
			2	Sea
			3	Air
			4	Stationary
			5	Automobile
4	reserved	UINT8	0xFF	do not alter
5-8	Elevation Mask	Single	0- p/2	Lowest satellite elevation for fixes (radians)
9-12	AMU Mask	Single		Minimum signal level for fixes
13-16	PDOP Mask	Single		Maximum DOP for fixes
17-20	PDOP Switch	Single		Switches 2D/3D mode
21	reserved	UINT8	0xFF	do not alter
22	Foliage Mode	UINT8	0	Never
			1	Sometimes
			2	Always
23	reserved	UINT8	0xFF	do not alter
24	reserved	UINT8	0xFF	do not alter
25	reserved	UINT8	0xFF	do not alter
26	reserved	UINT8	0xFF	do not alter
27-39	reserved	UINT8	0xFF	do not alter

C

CAUTION – The operation of ThunderBolt E can be affected adversely if incorrect data is entered in the fields associated with packet 0xBB.

Note – When sending packet 0xBB, fields that are specified as "do not alter" or if you do not want to alter a specific field, send a value of 0xFF for UINT8 types and a value of -1.0 for floating point types. ThunderBolt E will ignore these values.

Command Packet 0xBC: Set Port Configuration

TSIP packet 0xBC is used to set and query the port characteristics. In query mode, packet 0xBC is sent with a single data byte and returns report packet 0xBC.

Note – The input and output baud rates must be the same.

Command Packet 0 x BC Data Format (Query Mode)

Byte	Item	Type	Value	Meaning
0	Port Number	UINT8	0	Port 1 (standard)
			1	Port 2 (not available)
			0xFF	Current port

The table below lists the individual fields within the packet 0xBC when used in the set mode and when read in the query mode.

Command and Report Packet 0xBC Field Data Format

Byte	Item	Type	Value	Meaning
0	Port to Change	UINT8	0	Port 1 (standard)
			1	Port 2 (factory only)
			0xFF	Current port
1	Input Baud Rate	UINT8	6	4800 baud
			7	9600 baud
			8	19200 baud
			9	38400 baud
			10	57600 baud
			11	115200 baud
2	Output Baud Rate	UINT8	As above	As above
3	# Data Bits	UINT8	2	7 bits
			3	8 bits
			4	8 bits
4	Parity	UINT8	0	None
			1	Odd
			2	Even
5	# Stop Bits	UINT8	0	1 bit
			1	2 bits

Byte	Item	Type	Value	Meaning
6	Flow Control	UINT8	0	None
7	Input Protocols	UINT8	0	None
			2	TSIP
8	Output Protocols	UINT8	0	None
			2	TSIP
9	Reserved	UINT8	0	Reserved

TSIP Superpackets

Several packets have been added to the core TSIP protocol to provide additional capability for the receivers. In packets 0x8E and their 0x8F responses, the first data byte is a subcode which indicates the superpacket type. For example, in packet 0x8E-15, 15 is the subcode that indicates the superpacket type. Therefore the ID code for these packets is 2 bytes long followed by the data.

Command Packet 0x8E-15: Request current Datum values

This packet contains only the subpacket ID, 0x15. The response to this packet is 0x8F-15.

Command Packet 0x8E-26: Write Configuration to NVS

This command packet causes the current configuration settings for all user segments to be written to NVS.

Note – The ThunderBolt E configuration settings are partitioned into functional areas (segments) each of which can be saved individually via Command Packet 0x8E-4C or set to defaults via Command Packet 0x8E-45.

Command Packet 0x8E-41: Request Manufacturing Parameters

This packet is used to request the manufacturing parameters stored in non-volatile memory. Send this packet with no data bytes (don't forget the subcode) to request packet 0x8F-41.

Command Packet 0x8E-42: Stored Production Parameters

This packet is used to request the production parameters stored in non-volatile memory. Send this packet with no data bytes (don't forget the subcode) to request packet 0x8F-42.

Command Packet 0x8E-45: Revert Configuration Segment to Default Settings and Write to NVS

This command packet causes the current configuration settings for the specified user segment (or all segments) to revert to their factory defaults and written to NVS. The receiver is also re-configured with the default settings. The segment ID is contained in a data byte.

Byte	Item	Type	Value	Meaning
0	Subcode	UINT8	0x45	
1	Segment ID	UINT8	3	GPS Receiver config
			4	Packet I/O control
			5	Serial Port config
			6	Timing Output config
			7	Accurate Position
			8	Self-Survey config
			9	Disciplining config
			0xFF	All segments

Command Packet 0x8E-4A: Set PPS Characteristics

This packet allows the user to query (by sending the packet with no data bytes) or set PPS characteristics. The receiver responds to a query or set command with packet 0x8F-4A.

Byte	Item	Type	Value	Meaning
0	Subcode	UINT8	0x4A	
1	PPS driver switch	UINT8	0	off
			1	on
2	Reserved	UINT8		
3	PPS polarity	UINT8	0	positive
			1	negative
4-11	PPS offset or cable delay ¹	Double		seconds
12-15	Bias uncertainty threshold	Single	300.0	meters

¹Negative offset values advance the PPS, and are normally used to compensate for cable delay. Useful values for the PPS offset are between ± 50 ms. Units are in seconds and be entered as a decimal or scientific exponent, for example, as 0.00000005, $50e^{-9}$ or $50e^{-8}$ that all represent a 50 ns delay.

Command Packet 0x8E-4C: Write Configuration Segment to NVS

This command packet causes the current configuration settings for the specified user segment (or all segments) to be written to NVS. The segment ID is contained in a data byte.

Byte	Item	Type	Value	Meaning
0	Subcode	UINT8	0x4C	
1	Segment ID	UINT8	3	GPS Receiver config
			4	Packet I/O control
			5	Serial Port config
			6	Timing Output config
			7	Accurate Position
			8	Self-Survey config
			9	Disciplining config
			0xFF	All segments

Command Packet 0x8E-4E: Set PPS output option

This command packet sets the PPS driver switch to one of the values listed below. The current driver switch value can be requested by sending the packet with no data bytes except the subcode byte.

Driver switch values 3 and 4 only make sense in Over-Determined Timing mode. In any position fix mode the effective choices are always on or during fixes which you get if you set the driver switch to 3 or 4.

ThunderBolt E can also be configured to generate an Even Second pulse in place of the PPS pulse by setting the value as shown in the table below.

Byte	Item	Type	Value	Meaning
0	Subcode	UINT8	0x4E	
1	PPS driver switch	UINT8	0x02	PPS is always on.
			0x03	PPS is generated every second. PPS is output when at least one satellite is tracking.
			0x04	PPS is generated every second PPS is output when at least three satellites are tracking.
			0x82	PPS is always on. PPS is generated every even second.
			0x83	PPS is output when at least one satellite is tracking. PPS is generated every even second.
			0x84	PPS is output when at least three satellites are tracking. PPS is generated every even second.

Command Packet 0x8E-A0: Set DAC Value

Use command packet 0x8E-A0 to set the DAC output voltage or to request the current DAC output voltage plus the parameters describing the DAC. The DAC output voltage is used to control the frequency of the OCXO (Oven Controlled Crystal Oscillator.) Send this packet with no data to request the DAC voltage. The receiver responds with packet 0x8F-A0.

The Command Packet Data Fields are as follows:

Field	Description	Setting
Voltage/Value flag	Use this field to specify that the DAC is to be set either by value or by voltage.	0: Set DAC by voltage 1: Set DAC by value
DAC Voltage Value:	When the Voltage/Value Flag is set to voltage, use this field to specify the numeric value of the DAC as the 32-bit unsigned number.	Voltage: 0.0 V to +4.0 V Value: 0x00000 to 0xFFFFF (20 bits)

To set the DAC voltage, send packet 0x8E-A0 in the format shown below.

Note – Oscillator disciplining must be disabled (see packet 0x8E-A3) to use this command to set the DAC voltage.

Command Packet 0x8E-A0 Data Format

Byte	Item	Type	Value	Description
0	Subcode	UINT8	0xA0	
1	Voltage /Value Flag	UINT8	0 1	Set DAC voltage Set DAC value
2-5	DAC Voltage/ Value	Single/UINT3 2		DAC voltage/Value

Command Packet 0x8E-A2: UTC/GPS Timing

Command packet 0x8E-A2 sets the UTC/GPS timing mode (time and date fields) in packet 0x8F-AB, and the temporal location of ThunderBolt E output PPS. Send packet 0x8E-A2 with no data to request the current settings. The receiver replies with response packet 0x8F- A2.

Byte	Bit	Item	Type	Value	Meaning
0		Subcode	UINT8	0xA2	
1	0	UTC/GPS time	bit field	0	GPS time/date in packet 0x8F-AB
	1			1	UTC time/date in packet 0x8F-AB
			bit field	0	PPS referenced to GPS time
				1	PPS referenced to UTC time

Command Packet 0x8E-A3: Issue Oscillator Disciplining Command

Use command packet 0x8E-A3 to issue an oscillator disciplining command. The receiver responds with packet 0x8F-A3 in the same format as packet 0x8E-A3.

Byte	Item	Type	Value	Description
0	Subcode	UINT8	0xA3	
1	Disciplining Command	UINT8	0	Place PPS on time (jam sync)
			1	Transition to recovery state
			2	Transition to manual holdover
			3	Transition from manual holdover
			4	Disable oscillator disciplining
			5	Enable oscillator disciplining.

Command Packet 0x8E-A4: Test Modes

ThunderBolt E provides a test mode of operation that allows the user to set the time and UTC parameters. Packet 0x8F-AC provides a status bit (minor alarm bit 8) to warn the user that ThunderBolt E is operating in a test mode. The receiver replies with response packet 8F-A4.

Note – Test mode 3 does not actually cause the receiver to enter a test mode, but instead provides a means for the user to send UTC parameters to the receiver that will be used in test mode 1.

Test mode	Data field	Description
0	Test mode	Set this field to 0 to exit test mode and return the receiver to normal operations. A reset or power cycle will also cause the receiver to exit test mode.
1	Test mode	Setting this field to 1 tells the receiver to enter the user time test mode. The receiver will set the time to the week number and TOW sent with this packet. The receiver will then increment this time once per second. The time in packet 8F-AB will show the user test time, but all other packets that have time fields will be unaffected.
	Week number	This field contains the week number for the user time test mode.
	Time-of-Week	This field contains the TOW for the user time test mode.
3	Note - For a more detailed description of UTC parameters, see GPS SPS Signal Specification	
	Test Mode	Setting this field to 3 tells the receiver that the following fields contain the user UTC parameters that are to be used while in test mode 1.
	A_0	This field is the fractional second offset of GPS from UTC at the reference time in seconds.
	A_1	This field is the rate of change of fractional second offset of GPS from UTC in seconds/second.
	delta_t_LS	Current integer leap seconds.

Test mode	Data field	Description
	t_ot	This field is the reference time-of-week for the A_0/A_1 parameters.
	WN_t	This field is the reference week number for the A_0/A_1 parameters.
	WN_LSF	This field is the week number of a future leap second event.
	DN	This field is the day number of a future leap second event.
	delta_t_LSF	This field is the integer number of future leap seconds.

Command Packet 0x8E-A4 Test Mode 0 Data Format

Byte	Item	Type	Description
0	Subcode	UINT8	0xA4
1	Test Mode	UINT8	0 = Exit test mode

Command Packet 0x8E-A4 Test 1 Mode 1 Data Format

Byte	Item	Type	Description
0	Subcode	UINT8	0xA4
1	Test Mode	UINT8	1 = Set absolute time, ignore GPS time
2-3	Week Number	UINT16	Week number (0-1023)
4-7	Time of Week	UINT32	Seconds (0-604799)

Command Packet 0x8E-A4 Test Mode 3 Data Format

Byte	Item	Type	Description
0	Subcode	UINT8	0xA4
1	Test Mode	UINT8	3 = Send user UTC parameter
2-5	A_0	Single	Seconds
6-9	A_1	Single	Seconds/second
10-11	delta_t_LS	SINT16	Seconds
12-15	t_ot	UINT32	Seconds
16-17	WN_t	UINT16	Week number
18-19	WN_LSF	UINT16	Week number
20-21	DN	UINT16	Day number (1-7)
22-23	delta_t_LSF	SINT16	Seconds

Command Packet 0x8E-A5: Packet Broadcast Mask

Use command packet 8E-A5 to set the packet broadcast masks or to request the current mask settings. The receiver replies to requests with response packet 8F-A5. The broadcast mask is bitwise encoded to allow the user to turn on and off the broadcast of certain packets. For each bit in the mask that is used, the coding is as follows:

0: Turn off broadcast of this packet

1: Turn on broadcast of this packet

Byte	Bit	Item	Type	Description
0		Subcode	UINT8	0xA5
1-2	0	Mask 0	bit field	8F-AB, Primary Timing Information
	1			Reserved
	2			8F-AC, Supplemental Timing Information
	3			Reserved
	4			Reserved
	5			Reserved
	6			Automatic Output Packets
3-4		Mask 2	bit field	Reserved

Command Packet 0x8E-A6: Self-Survey Command

Use command packet 8E-A6 to issue a self-survey command to save the current position in flash, or to delete the position saved in flash. There is no response to this packet.

Byte	Item	Type	Value	Meaning
0	Subcode	UINT8	0xA6	
1	Self-survey command	UINT8	0	Restart self-survey
			1	Save position to flash
			2	Delete position from flash

Command Packet 0x8E-A8: Set or Request Disciplining Parameters

This packet allows the user to change key disciplining parameters in the receiver. It is usually intended to be used only when instructed by the factory. Incorrect use of this packet will most likely cause timing outputs to be degraded severely. However, the "Type 2" (Recovery Mode) parameters are intended to be set by the user to suit the application. Send this packet with the type field only to request the current settings. The receiver replies to sets and requests with the packet 0x8F A8.

Type	Data field	Description
0	Type	A zero in this field indicates that the packet contains loop dynamics information.
	Time Constant	This field carries the time constant of the disciplining control loop
	Damping Factor	This field carries the damping of the disciplining control loop.
1	Type	A "1" in this field indicates that the packet contains 10MHz oscillator parameters.
	EXCO Constant	This field carries the OCXO constant into Hz/Volt. The receiver determines this value automatically during a calibration step run during the Power-Up mode following a reset or power cycle. This value is therefore ignored by the ThunderBolt E.
	OCXO Minimum Control Voltage	This field carries the minimum (most negative) control voltage that can be applied to the 10 MHz oscillator's control voltage input.
	OCXO Maximum Control Voltage	This field carries the maximum (most positive) control voltage that can be applied to the 10 MHz oscillator's control voltage input.

Type	Data field	Description
2	Type	A "2" in this field indicates that the packet contains Recovery Mode parameters. These parameters allow the user to control the recovery process. During Recovery, The receiver will remove any PPS offset accumulated during periods of Holdover by either shifting the PPS into alignment or by shifting the frequency of the 10 MHz oscillator by a specified amount until the PPS has slewed back into alignment or by using both methods. The following two parameters control these methods: <ul style="list-style-type: none"> • If a fast recovery is desired, allow jam syncs to be used • If it is important to maintain 10 million clock cycles per PPS pulse, then disable jam syncs and set the maximum frequency offset to a tolerable value.
	Jam Sync Threshold	This field carries the jam sync threshold in nanoseconds used during Recovery mode. While in Recovery Mode, if the PPS offset is above this threshold, The receiver will automatically perform a jam sync to shift the PPS into alignment with GPS. The minimum allowed value is 50 nanoseconds. Setting a value less than or equal to 0 nanoseconds will disable automatic jam syncs during Recovery (though the user can still issue a jam sync command with packet 0x8E-A3).
	Maximum Frequency Offset	This field carries the maximum allowable frequency offset in ppb (parts per billion, or 1×10^{-9}) of the 10 MHz oscillator during Recovery Mode. While in Recovery Mode, The receiver will remove any PPS offset accumulated during periods of Holdover by shifting the frequency of the oscillator by an amount up to the value specified. The minimum allowed value is 5ppb.
3	Type	A "3" in this field indicates that the packet contains the initial DAC voltage parameter.
	Initial DAC voltage	At reset, the oscillator's frequency control voltage is set to this value

Command Packet 0x8E-A8 Type 0 Data Format

Byte	Item	Type	Description
0	Subcode	UINT8	0xA8
1	Type	UINT8	0 = loop dynamics
2-5	Time Constant	Single	Seconds
6-9	Damping Factor	Single	Dimensionless

Command Packet 0x8E-A8 Type 1 Data Format

Byte	Item	Type	Description
0	Subcode	UINT8	0xA8
1	Type	UINT8	1 = oscillator parameters
2-5	Oscillator Gain Constant	Single	Hz/Volt
6-9	Minimum Control Voltage	Single	Volts
10-13	Maximum Control Voltage	Single	Volts

Command Packet 0x8E-A8 Type 2 Data Format

Byte	Item	Type	Description
0	Subcode	UINT8	0xA8
1	Type	UINT8	2 = recovery mode parameters
2-5	Jam Sync Threshold	Single	nanoseconds
6-9	Maximum Frequency Offset	Single	ppb (parts per billion or 1x10 ⁻⁹)

Command Packet 0x8E-A8 Type 3 Data Format

Byte	Item	Type	Description
0	Subcode	UINT8	0xA8
1	Type	UINT8	3 = initial DAC voltage
2-5	Initial DAC voltage	Single	Volts

Command Packet 0x8E-A9: Self-Survey Parameters

Use command packet 8E-A9 to set the self-survey parameters or to request the current settings. The receiver replies to requests with response packet 8F-A9.

Data field	Description
Self-Survey Enable	Use this field to enabled or disabled the self-survey mechanism. 0: Disable the self-survey mechanism 1: Enable the self-survey mechanism
Position Save Flag	Use this field to tell the self-survey mechanism to automatically save (or to not save) the self-surveyed position at the end of the self-survey procedure. This flag also determines how the The receiver will respond to the saved position it is using for Over-Determined Clock Mode when the position appears questionable (i.e. if the position may off by a large amount.) If the flag is set to 0, then a questionable position will be flagged in packet 0x8F-AC. If the flag is set to 1, then a questionable position will automatically be deleted. 0: Don't automatically save the surveyed position when self-survey is complete 1: Automatically save the surveyed position when self-survey is complete.
Self-Survey Length	Use this field to specify the number of position fixes that are to be averaged together to form the self-surveyed position used for clock-only fixes. Limits: 1 to (232 - 1) fixes.

Command Packet 8E-A9 Data Format

Byte	Item	Type	Value	Description
0	Subcode	UINT8	0xA9	
1	Self-Survey Enable	UINT8	0 1	Disabled Enabled
2	Position Save Flag	UINT8	0 1	Don't save position Save self-surveyed position at the end of the survey
3-6	Self-Survey Length	UINT32	see above	Number of fixes
7-10	Reserved	UINT32	0	0

Command Packet 0x8E-AB: Request Primary Timing Packet

Use command packet 0x8E-AB to request the Primary Timing packet 0x8F-AB. By default, the receiver automatically sends packet 0x8F-AB once per second so it is not necessary to request it. To receive 0x8F-AB information by request only, use packet 0x8E-A5 to disable the automatic output.

The Request Type item determines how the receiver will reply to this command:

Type	Description
0	The most current primary timing values will be sent in packet 0x8F-AB immediately.
1	The response is not sent immediately. Instead packet 0x8F-AB is sent after the next PPS output. This is the same time that the packet would be automatically sent if enabled.
2	Same as type 1 except that both 0x8F-AB and 0x8F-AC are sent after the next PPS output.

Command Packet 0x8E-AB Data Format

Byte	Item	Type	Value	Meaning
0	Subcode	UINT8	0xAB	
1	Request type	UINT8	0 1 2	Send 0x8F-AB immediately Send 0x8F-AB on-time next second Send 0x8F-AB and 0x8F-AC on-time next second

Command Packet 0x8E-AC: Request Supplementary Timing Packet

Use command packet 8E-AC to request the Supplemental Timing packet 0x8F-AC. By default, the receiver automatically sends packet 0x8F-AC once per second so it is not necessary to request it. To receive 0x8F-AC information by request only, use packed 0x8E-A5 to disable the automatic output.

The Request Type item determines how the receiver will reply to this command:

Type	Description
0	The most current primary timing values will be sent in packet 0x8F-AC immediately.
1	The response is not sent immediately. Instead packet 0x8F-AC is sent after the next PPS output. This is the same time that the packet would be automatically sent if enabled.
2	Same as type 1 except that both 0x8F-AB and 0x8F-AC are sent after the next PPS output.

Command Packet 0x8E-AC Data Format

Byte	Item	Type	Value	Meaning
0	Subcode	UINT8	0xAC	
1	Request type	UINT8	0	Send 0x8F-AC immediately
			1	Send 0x8F-AC on-time next second
			2	Send 0x8F-AB and 0x8F-AC on-time next second

Report Packet 0x8F-15 Current Datum Values

This packet contains the values for the datum currently in use and is sent in response to packet 8E-15. If a built-in datum is being used, both the datum index and the five double-precision values for that index are returned. If the receiver is operating on a custom user-entered datum, the datum index is set to -1 and the five values are displayed. These five values describe an ellipsoid to convert ECEF XYZ coordinate system into LLA.

Byte	Type	Value	Description
0	Super Packet ID	14	
1-2	Datum index (-1 for custom)	Datum Index	
3-10	DOUBLE	DX	meters
11-18	DOUBLE	DY	meters
19-26	DOUBLE	DZ	meters
27-34	DOUBLE	A-axis	meters
35-42	DOUBLE	Eccentricity squared	none

Report Packet 0x8F-41: Stored Manufacturing Operating Parameters

This packet is sent in response to a command 0x8E-41.

Byte	Item	Type	Value
0	Subcode	UINT8	0x41
1-2	Reserved	UINT16	
3-6	Board serial number	UINT32	
7	Year of build	UINT8	
8	Month of build	UINT8	
9	Day of build	UINT8	
10	Hour of build	UINT8	
11-14	Reserved	Single	
15-16	Reserved	UINT16	

Report Packet 0x8F-42: Stored Production Parameters

This packet is sent in response to 0x8E-42.

Byte	Item	Type	Value
0	Subcode	UINT8	0x42
1	Reserved	UINT8	
2	Reserved	UINT8	
3-4	Reserved	UINT16	
5-8	Reserved	UINT32	
9-12	Reserved	UINT32	
13-14	Reserved	UINT16	
15-16	Reserved	UINT16	
17-18	Reserved	UINT16	

Report Packet 0x8F-4A: Set PPS Characteristics

This is sent in response to a query by packet 0x8E-4A. See the corresponding command packet for information about the data format.

Report Packet 0x8F-4E: PPS Output

This report packet is output after the command packet 8E-4E has been executed. See the corresponding command packet for information about the data format.

Report Packet 0x8F-A0: DAC Value

This packet is sent in response to packet 0x8E-A0.

Data field	Description
DAC Value:	The current numeric value of the DAC.
DAC Voltage	The current output voltage of the DAC in Volts.
DAC Resolution	The number of bits used in the DAC.
DAC Data Format	The format of the DAC value.
	Minimum DAC Voltage: The minimum (most negative) voltage that the DAC can produce.
	Maximum DAC Voltage: The maximum (most positive) voltage that the DAC can produce

Report Packet 0x8F-A0 Data Format

Byte	Item	Type	Value	Description
0	Subcode	UINT8	0xA0	
1-4	DAC Value	UINT32		Value
5-8	DAC Voltage	Single		Volts
9	DAC Resolution	UINT8		Number of bits
10	DAC data format	UINT8	0	Offset binary
			1	2's complement
11-14	Min DAC voltage	Single		Volts
15-18	Max DAC voltage	Single		Volts

Report Packet 0x8F-A2: UTC/GPS Timing

This packet is sent in response to command packet 0x8E-A2. See the corresponding command packet for information about the data format.

Report Packet 0x8F-A3: Oscillator Disciplining Command

This packet is sent in response to command packet 0x8E-A3. See the corresponding command packet for information about the data format.

Report Packet 0x8F-A4: Test Modes

This packet is sent in response to command packet 0x8E-A4. See the corresponding command packet for information about the data format.

Report Packet 0x8F-A5: Packet Broadcast Mask

This packet is sent in response to 0x8E-A5 command and describes which packets are currently automatically broadcast. A '0' in a bit field turns off broadcast, and a '1' in a bit field enables broadcast. See the corresponding command packet for information about the data format.

Report Packet 0x8F-A6: Self-Survey Command

This packet is sent in response to command packet 0x8E-A6. See the corresponding command packet for information about the data format.

Report Packet 0x8F-A8: Oscillator Disciplining Parameters

This packet is sent in response to command packet 0x8E-A8. See the corresponding command packet for information about the data format.

Report Packet 0x8F-A9: Self-Survey Parameters

Packet 0x8F-A9 is sent in response to command packet 0x8E-A9 and describes the current self-survey parameters. See the corresponding command packet for information about the data format.

Report Packet 0x8F-AB: Primary Timing Packet

This packet provides time information once per second. GPS week number, GPS time-of-week (TOW), UTC integer offset, time flags, date and time-of-day (TOD) information is provided. This packet can be requested or enabled for automatic broadcast once per second. If enabled, this packet will be transmitted shortly after the PPS pulse to which it refers.

Data field	Description
Time of Week	This field represents the number of seconds since Sunday at 00:00:00 GPS time for the current GPS week. Time of week is often abbreviated as TOW.
Week Number	This field represents the current GPS week number. GPS week number 0 started on January 6, 1980.
UTC Offset	This field represents the current integer leap second offset between GPS and UTC according to the relationship: Time (UTC) = Time (GPS) - UTC Offset. The UTC offset information is reported to the receiver by the GPS system and can take up to 12.5 minutes to obtain. Before the receiver has received UTC information from the GPS system, it is only capable of representing time in the GPS time scale, and the UTC offset will be shown as 0.
Timing Flags:	<p>This field is bitwise encoded to provide information about the timing outputs. Unused bits are should be ignored.</p> <ul style="list-style-type: none">• Bit 0: When 0, the date and time fields broadcast in packet 8F-AB are in the GPS time scale. When 1, these fields are in the UTC time scale and are adjusted for leap seconds. Use command packet 8E-A2 to select either GPS or UTC time scales.• Bit 1: When 0, the PPS output is aligned to GPS. When 1, the PPS output is aligned to UTC. Use command packet 8E-A2 to select either GPS or UTC PPS alignment.• Bit 2: When 0, time has been set from GPS. When 1, time has net yet been set from GPS.• Bit 3: When 0, UTC offset information has been received. When 1, UTC offset information is not yet known.• Bit 4: When 0, time is coming from GPS. When 1, The receiver is in a test mode and time is being generated by the test mode selected by the user. See packet 8E-A4, Test Modes.

Data field	Description
Time of Day	The time of day is sent in hours-minutes-seconds format and varies from 00:00:00 to 23:59:59, except when time is in UTC and a leap second insertion occurs. In this case the time will transition from 23:59:59 to 23:59:59 to 00:00:00. Use command packet 8E-A2 to select either the GPS or UTC time scale.
Date	The date is sent in day-month-year format. Use command packet 8E A2 to select either the GPS or UTC time scale.

Report Packet 0x8F-AB

Byte	Bit	Item	Type	Value	Description
0		Subcode	UINT8		0xAB
1-4		Time of week	UINT32		GPS seconds of week
5-6		Week Number	UINT16		GPS Week Number
7-8		UTC Offset	SINT16		UTC Offset (seconds)
9	0	Timing Flag	bit field	0	GPS time
				1	UTC time
	1			0	GPS PPS
				1	UTC PPS
	2			0	time is set
				1	time is not set
	3			0	have UTC info
				1	no UTC info
4	0	time from GPS			
	1	time from user			
10		Seconds	UINT8	0-59	Seconds
11		Minutes	UINT8	0-59	Minutes
12		Hours	UINT8	0-23	Hours
13		Day of Month	UINT8	1-31	Day of Month
14		Month	UINT8	1-12	Month of Year
15-16		Year	UINT16		Four digits of Year

Report Packet 0x8F-AC: Supplemental Timing Packet

This packet provides supplemental timing information once per second. Information regarding position, unit status and health, and the operational state of the unit is provided. This packet can be requested or enabled for automatic broadcast once per second. When enabled, this packet is transmitted once per second shortly after packet 0x8F-AB.

The position sent in packet 0x8F-AC depends on the Receiver Operating Mode and on self-survey activity. When a self-survey is in progress, the position sent is the running average of all of the position fixes collected so far. When the self-survey ends or whenever the receiver is using a time-only operating mode, then the position sent is

the accurate position the receiver is using to perform time-only fixes. When the self-survey is disabled or otherwise inactive and the receiver is using a position fix operating mode, then the position sent is the position fix computed on the last second.

Data field	Description
Receiver Mode	This field shows the fix mode that the GPS receiver is currently configured for. The receiver spends most of its time in the Over-Determined Clock Mode where it uses all available satellites to perform the best time-only fix possible. See packet 0xBB for a description of all available receiver modes.
Self-Survey Progress	When a self-survey procedure is in progress, this field shows the progress of the survey as a percentage of fixes collected so far. The self-survey will be complete when the self-survey progress reaches 100 percent. This field only has meaning while a self-survey is in progress.
Holdover Duration	When in the Manual or Auto Holdover state, this field shows the amount of time spent in holdover in seconds. When the unit is not in a holdover state, this field shows the amount of time the receiver spent the last time it was in a holdover state.
Critical Alarms	This field is bitwise encoded with critical alarms indicators. A critical alarm indicates a condition that would tend to severely impair the function of the receiver. For each bit, a value of 0 means that the condition is not indicated. Bits not described below should be ignored. Bit4: When 1, indicates that the oscillator control voltage is at a rail. If this condition persists then the Min-T can no longer bring the frequency of the oscillator into alignment with GPS and is most likely in need of a new oscillator. This condition should not occur within 15 years of operation.
Minor Alarms	This field is bitwise encoded with several minor alarm indicators. A minor alarm indicates a condition that the user should be alerted to, but does not indicate an immediate (or necessarily any) impairment of functionality. For each bit, a value of 0 means that the condition is not indicated. Bits not described below should be ignored. <ul style="list-style-type: none"> • Bit 0: When 1, indicates that the oscillator control voltage is near a rail. If this condition persists, then the oscillator is within 2 years of becoming untunable, at which point the unit will need a new oscillator. This condition should not occur for at least 12 years of use and is a result of oscillator crystal aging. • Bit 1: When 1, indicates that the antenna input connection is open. More precisely, this bit indicates that the antenna input is not drawing sufficient current. Normally, The receiver provides power to the antenna's LNA (Low Noise Amplifier) through the center conductor of the antenna cable. On-board circuitry senses this current draw, and if low, this condition will be indicated. However, when the antenna is powered elsewhere (e.g., when using a splitter) then an antenna open condition is expected and does not imply a fault nor does it impair the operation of the receiver. • Bit 2: When 1, indicates that the antenna input is shorted. More precisely, this bit indicates that the antenna input is drawing too much current. On-board protection circuitry prevents any damage to The receiver when its antenna input is shorted to ground. This condition tends to indicates a fault in either the antenna cable or the antenna itself. • Bit 3: When 1, indicates that no satellites are usable. In order for a satellite to be usable, it must be tracked long enough to obtain ephemeris and health data. • Bit 4: When 1, indicates that the oscillator is not being disciplined to GPS. Before the Mini- T can begin disciplining the oscillator, it must begin receiving information from the GPS receiver. This occurs any time that the receiver is performing fixes. • Bit 5: When 1, indicates that a self-survey procedure is in progress. • Bit 6: When 1, indicates that there is no accurate position stored in flash ROM. • Bit 7: When 1, indicates that the GPS system has alerted the receiver that a leap second transition is pending.

Data field	Description
Minor Alarms (cont.)	<ul style="list-style-type: none"> Bit 8: When 1, indicates that The receiver is operating in one of its test modes (see packet 0x8E- A4.) Bit 9: When 1, indicates that the accuracy of the position used for time only fixes is questionable. This alarm may indicate that the unit has been moved since the unit completed the last self-survey. If this alarm persists, re-survey the position of the unit. Bit 10: When 1, indicates that at reset, one or more EEPROM segments were found to be corrupt and had to be set to factory default settings. Use packet 0x3F-11 / 5F-11 to retrieve details about which segments were corrupt and to clear this bit.
GPS Decoding Status	This field indicates the decoding status of the GPS receiver.
Disciplining Activity	This field indicates the current activity of the disciplining mechanism.
PPS Offset	This field carries the estimate of the offset of the PPS output relative to UTC or GPS as reported by the GPS receiver in nanoseconds. Positive values indicate that the receiver's PPS is coming out late relative to GPS or UTC.
Frequency Offset	This field carries the estimate of the frequency offset of the 10MHz output relative to UTC or GPS as reported by the GPS receiver in ppb (parts-per-billion.) Positive values indicate that the receiver's clock is running slow relative to GPS or UTC.
DAC Value	This field shows the numeric value of the DAC used to produce the voltage that controls the frequency of the 10MHz oscillator.
DAC Voltage	This field shows the voltage output of the DAC.
Temperature	This field shows the temperature (in Celsius) as reported by the receiver's on-board temperature sensor.
Latitude	This field carries the latitude of the position being shown. The units are in radians and vary from $-\pi/2$ to $+\pi/2$. Negative values represent southern latitudes. Positive values represent northern latitudes.
Longitude	This field carries the longitude of the position being shown. The units are in radians and vary from $-\pi$ to $+\pi$. Negative values represent western longitudes. Positive values represent eastern longitudes.
Altitude	This field carries the altitude of the position being shown. The units are in meters (WGS-84.)
PPS Quantization Error	This field carries the PPS quantization error in units of nanoseconds of an internal PPS signal. This value is not useful on a ThunderBolt E since the PPS output is derived from a disciplined oscillator and therefore does not have any quantization error

Report Packet 0x8F-AC

Byte	Item	Type	Value	Description
0	Subcode Receiver Mode	UINT8	0xAC	
			0	Automatic (2D/3D)
			1	Single Satellite (Time)
			3	Horizontal (2D)
			4	Full Position (3D)
2	Disciplining Mode	UINT8	7	Over-Determined Clock
			0	Normal (Locked to GPS)
			1	Power Up
			2	Auto Holdover
			3	Manual Holdover
			4	Recovery

Byte	Item	Type	Value	Description
			5	Not used
			6	Disciplining Disabled
3	Self-Survey Progress	UINT8		0-100%
4-7	Holdover Duration	UINT32	0	Seconds
8-9	Critical Alarms	UINT16	Bit field	Bit 4: DAC at rail
10-11	Minor Alarms	UINT16	Bit field	Bit 0: DAC near rail Bit 1: Antenna open Bit 2: Antenna shorted Bit 3: Not tracking satellites Bit 4: Not disciplining oscillator Bit 5: Survey-in progress Bit 6: No stored position Bit 7: Leap second pending Bit 8: In test mode Bit 9: Position is questionable Bit 10: Not used Bit 11: Almanac not complete Bit 12: PPS not generated
12	GPS Decoding Status	UINT8	0x00	Doing fixes
			0x01	Don't have GPS time
			0x03	PDOP is too high
			0x08	No usable sats
			0x09	Only 1 usable sat
			0x0A	Only 2 usable sats
			0x0B	Only 3 usable sats
			0x0C	The chosen sat is unusable
			0x10	TRAIM rejected the fix
13	Disciplining Activity	UINT8	0	Phase locking
			1	Oscillator warm-up
			2	Frequency locking
			3	Placing PPS
			4	Initializing loop filter
			5	Compensating OCXO (holdover)
			6	Inactive
			7	Not used
			8	Recovery mode
			9	Calibration/control voltage
14	Spare Status 1	UINT8	0	
15	Spare Status 2	UINT8	0	
16-19	PPS Offset	Single		ns
20-23	Clock Offset	Single		ppb
24-27	DAC Value	UINT32		

Byte	Item	Type	Value	Description
28-31	DAC Voltage	Single		Volts
32-35	Temperature	Single		degrees C
36-43	Latitude	Double		radians
44-51	Longitude	Double		radians
52-59	Altitude	Double		meters
60-63	PPS Quantization Error	Single		ns
64-67	Spare			Future expansion

Calibration and Traceability

In this appendix:

- Traceability of ThunderBolt GPS-DO clock to national standards
- Chain of authority

It is not necessary to calibrate the ThunderBolt GPS-DO clock, providing that:

- The ThunderBolt unit is operating in disciplined mode.
- The GPS satellites being used are healthy
- The ThunderBolt unit is not defective

Under these constraints, the double-ovenized crystal oscillator (DOXCO) contained in the ThunderBolt E clock is monitored and "disciplined" to follow the atomic clocks on board the GPS satellites. These satellite clocks are controlled by the GPS master control station to match the GPS master clock, which is, in turn steered to match UTC (USNO). An unbroken chain is then maintained between the ThunderBolt and the US official time source.

Calibration is the common way for standards to be related to national standards ("tracability"). In this case tracability is achieved by the inherent operation of the GPS satellites and the ThunderBolt E clock. Hence the emphasis on creating log files as audit trails so that correct "health" of the satellites and correct operation of the ThunderBolt can be verified for the period during which a calibration of another piece of equipment takes place.

Traceability of ThunderBolt GPS-DO clock to national standards

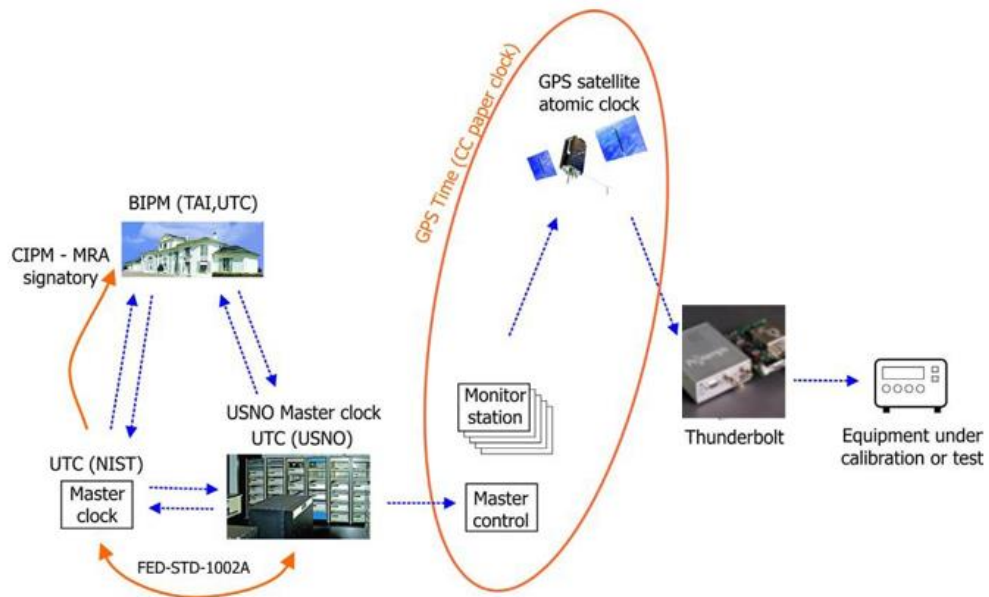

To complete the traceability picture for metrology, laboratories must maintain a set of records documenting the history and health of the system.

By using the Protempis GPS-DO clock and the Protempis GPS Studio software, a laboratory can document the traceability of a ThunderBolt-based test at all times.

Each GPS satellite broadcasts information about the whole constellation of satellites as part of the almanac. The ThunderBolt GPS-DO clock decodes this information and communicates it externally via the serial port using the TSIP protocol. You can use the Protempis GPS Studio software to display this information and store it periodically in a log file.

You must also monitor the ThunderBolt GPS-DO clock hardware and firmware. Again, the receiver health is constantly monitored and reported using the TSIP protocol. This data may appear in the Protempis GPS Studio and is incorporated in log files.

The *Timing Receiver Status and Control* screen, shown below, displays information about the health of a ThunderBolt GPS-DO frequency and timing reference clock. The screen layout makes it very easy to spot anything wrong with the equipment. Most of this information may be captured and stored to maintain an audit trail and traceability.



The Protempis GPS Studio software includes utilities to convert log files into other data formats. These formats enable the log information to be used in spreadsheets and databases. This capability extends the use of the information to other analysis systems.

Chain of authority

The following table illustrates the unbroken chain of traceability for a ThunderBolt GPS-DO clock, including the relationship to US national standards and international UTC as determined by the BIPM:

Item	Authority
BIPM (Bureau International des Poids et Mesures)	International weights and measures organization. Established by signed convention between nations.
National Metrology Institutes	Established by signatory status to CIPM - Mutual Recognition Arrangement (MRA).
NIST and UTC(NIST)	Established by US Government and by status as US signatory to CIPM MRA ¹
USNO and UTC(USNO)	Established by US Government, declaration by NIST, and by FED-STD-1002A. ^{2 3}
GPS Time	Maintained to specified relationship to UTC(USNO) and transferred to GPS satellites. ⁴
ThunderBoltThunderBolt GPS-DO Clock	Tracks GPS satellites to establish precise time used to discipline double-ovenized crystal oscillator.
1 PPS and 10 MHz	Electrical outputs determined by disciplined oscillator.

¹CIPM Mutual Recognition Agreement signatory status of NIST on behalf of the USA, <http://www.bipm.org/en/cipm-mra/signatories.html>, retrieved 14 February 2012.

²USNO Master Clock produces UTC(USNO), <http://www.usno.navy.mil/USNO/time/master-clock>, retrieved 14 February 2012.

³ NIST statement on the authority of time sources: "The United States Naval Observatory (USNO) maintains the U. S. Department of Defense reference for time and time interval. USNO has an ensemble of atomic clocks, which is used to derive a time scale called UTC(USNO). The clocks in the ensemble contribute to International Atomic Time (TAI) and Coordinated Universal Time (UTC). *UTC (USNO) and UTC (NIST) are kept in very close agreement, typically to within 20 nanoseconds, and both can be considered official sources for time in the United States.*", <http://www.nist.gov/pml/div688/utcnist.cfm>, retrieved 15 February 2012.

⁴ GPS interface standards document IS-GPS-200E, <http://www.gps.gov/technical/icwg/IS-GPS-200E.pdf>, retrieved 15 February 2012.

